

TM 5-3431-200-15

DEPARTMENT OF THE ARMY TECHNICAL MANUAL

OPERATOR, ORGANIZATIONAL
FIELD, AND DEPOT
MAINTENANCE MANUAL

**WELDING SET, ARC, INERT GAS
SHIELDED: PLASTIC OR METAL
LINED GUN; FOR 3/64 IN. WIRE;
DC, 115V (WESTINGHOUSE
MODEL SA-135) FSN 3431-879-9709**

This reprint includes all changes in
effect at the time of publication -
Changes 1 and 5.

HEADQUARTERS, DEPARTMENT OF THE ARMY
29 AUGUST 1962

SAFETY PRECAUTIONS

BEFORE OPERATION

Thoroughly clean the surfaces to be welded. Do not set up for welding in an area where fumes from flammable or toxic materials are present.

Disconnect the source of power from the welder before performing any electrical maintenance on the welding set.

DURING OPERATION

Do not attempt to weld unless a welding helmet and flash goggles are worn. The welding helmet should have a No. 10 or No. 12 shade welding plate. The flash goggles should have No. 2 shade lenses, with wide side shields.

Do not attempt to weld unless the skin is completely covered. Wear leather gloves to protect the hands. Wear light-weight leather clothing to protect the body. Leather resists deterioration from radiation. Do not wear cotton clothing or light colored clothing. If leather clothing is not available, wear heavy, dark colored clothing to prevent radiation from penetrating to the skin or from reflecting onto the neck under the helmet.

Do not weld in a closed area. Provide adequate ventilation against ozone gas poisoning. Take a regular break out of every welding hour to get some fresh air.

Provide adequate shielding for the work to protect the eyes of personnel working in the area.

AFTER OPERATION

Disconnect the source of power from the welder before performing any electrical maintenance on the welding set.

Performing any field expedient repair creates conditions possibly dangerous to personnel or equipment. A welding set so repaired should be taken out of service as soon as possible for replacement of defective parts.

When a malfunction of the selenium rectifier occurs, thoroughly ventilate the area to prevent the inhalation of poisonous fumes. Do not handle the damaged rectifier. Selenium oxide may be absorbed through the skin, especially when the rectifier is hot. Failure to observe this warning can result in severe illness or death.

CHANGE }
No. 5 }

HEADQUARTERS
DEPARTMENT OF THE ARMY
WASHINGTON, D. C., 7 December 1972

Operator, Organizational, Direct Support, General Support
and Depot Maintenance Manual

WELDING SET, ARC, INERT GAS; SHIELDED;
PLASTIC OR METAL LINED GUN FOR 3/64-IN.
WIRE; DC, 115V (WESTINGHOUSE MODEL
SA-135) FSN 3431-879-9709

TM 5-3436-200-15 29 August 1962, is
changed as follows:

Page 3. Paragraph 1d is superseded as follows:

d. You can improve this manual by calling attention to errors and by recommending improvements, using DA Form 2028 (Recommended Changes to Publications) or by a letter, and mail directly to Commander, U. S. Army Mobility Equipment Command, ATTN: AMSME-MPP, St. Louis, MO 63120. A reply will be furnished directly to you.

Paragraph 1e is superseded as follows:

e. Report all Equipment Improvement Recommendations as prescribed in TM 38-750.

Page 7. Paragraph 10(2)(a) is superseded as follows:

(a) Connect the welding current cable (fig 2) to the electrode terminal in the welder.

Page 47. Delete AR 750-5, Maintenance Responsibilities and Shop Operations.

Page 53. Appendix III is superseded as follows:

APPENDIX III
BASIC ISSUE ITEMS LIST AND ITEMS
TROOP INSTALLED OR AUTHORIZED

Section 1. INTRODUCTION

1. Scope

This appendix lists items required by the operator for operation of the welding set.

2. General

This list is divided into the following sections:

a. *Basic Issue Items List-section II.* Not applicable.

b. *Items Troop Installed or Authorized List-Section III.*

A list of items in alphabetical sequence, which at the discretion of the unit commander may accompany the welding set. These items are NOT SUBJECT TO TURN-IN with the welding set when evacuated.

3. Explanation of Columns.

The following provides an explanation of columns in the tabular list of Basic Issue Items List, Section II, and Items Troop Installed or Authorized, Section III.

a. *Source, Maintenance and Recoverability Code (SMR).* Not applicable.

b. *Federal Stock Number.* This column indicates the Federal stock number assigned to the item and will be used for requisitioning purposes.

c. *Description.* This column indicates the Federal item name and any additional description of the item required.

d. *Unit of Measure (U/M).* A two character alphabetic abbreviation indicating the amount or quantity of the item upon which the allowances are based, e.g., ft, ea, pr, etc.

e. *Quantity Furnished with Equipment (BIIL).* Not applicable.

f. *Quantity Authorized (Item Troop Installed or Authorized).*

This column indicates the quantity of the item authorized to be used with the equipment.

*This change superseded C 2, 7 March 1963, C 3, 9 January 1968 and C 4, 29 April 1964

Section III. ITEMS TROOP INSTALLED OR AUTHORIZED LIST

(1) SMR Code	(2) Federal stock number	(3) Description Ref No. & mfr code	(4) Unit of meas Usable on code	(5) Qty auth
	7520-559-9618	CASE, Maintenance and Operation Manual	EA	1

By Order of the Secretary of the Army:

Official:

VERNE L. BOWERS
Major General, United States Army
The Adjutant General

CREIGHTON W. ABRAMS
General, United States Army
Chief of Staff

Distribution:

To be distributed in accordance with DA Form 12-25A (qty rqr block no. 182) Organizational Maintenance requirements for Welding.

TECHNICAL MANUAL

Operator, Organizational, Field, and Depot Maintenance Manual
 WELDING SET, ARC, INERT GAS SHIELDED: PLASTIC OR METAL LINED GUN; FOR 3/64 IN.
 WIRE; DC, 115 V (WESTINGHOUSE MODEL SA-135) FSN 3431-879-9709

TM 5-3431-200-15 }
 CHANGES No. 1 }

HEADQUARTERS,
 DEPARTMENT OF THE ARMY,
 WASHINGTON 25, D. C., 12 February 1963

TM 5-3431-200-15, 29 August 1962, is changed as follows:

Page 3, paragraph 1d, lines 4 and 5. Delete "U. S. Army Engineer Maintenance Center, ATTN: EMCDDM-S", and substitute U. S. Army Mobility Support Center, ATTN: SMOMS-MS.

2. Record and Report Forms
 (Superseded)

a. DA Form 2258 (Depreservation Guide of Engineer Equipment).

b. For other record and report forms applicable to the operator and organizational maintenance, refer to TM 38-750.

Note. Applicable forms, excluding Standard Form 46, which is carried by the operator, will be kept in a canvas bag mounted on the equipment.

Page 7, paragraph 8a, line 1. Delete "before operation" and substitute *daily preventive maintenance*.

Page 10, paragraph 16a, lines 1 and 2. Delete "before operation" and substitute *daily preventive maintenance*.

Paragraph 17b. *Rescinded*.

28. General
 (Superseded)

To insure that the welding set is ready for operation at all times, it must be inspected systematically, so that defects may be discovered and corrected before they result in serious damage or failure. The necessary preventive maintenance services to be performed are listed and described in paragraphs 29 and 31. The item numbers indicate the sequence of minimum inspection requirements. Defects discovered during operation of the unit will be noted for

future correction, to be made as soon as operation has ceased, Stop operation immediately if a deficiency is noted during operation which would damage the equipment if operation were continued. All deficiencies and shortcomings will be recorded, together with the corrective action taken, on DA Form 2404 (Equipment Inspection and Maintenance Worksheet) at the earliest possible opportunity.

29. Daily Preventive Maintenance Services
 (Superseded)

This paragraph contains an illustrated tabulated listing or preventive maintenance services which must be performed by the operator. Daily services retain the same item numbers used in quarterly preventive maintenance services. Therefore, daily preventive maintenance services may not be numbered consecutively but should be performed in the numerical sequence as shown to insure complete coverage. Refer to figure 8 for the daily preventive maintenance services.

Paragraph 30. *Rescinded*.

31. Quarterly Preventive Maintenance Services
 (Superseded)

a. This paragraph contains an illustrated tabulated listing of preventive maintenance services which must be performed by organizational maintenance personnel at quarterly intervals. A quarterly interval is equal to 3 calendar months, or 250 hours of operation, whichever occurs first.

PREVENTIVE MAINTENANCE SERVICES

DAILY

TM5-3431-200-15

WESTINGHOUSE MODEL SA-135

WELDING SET

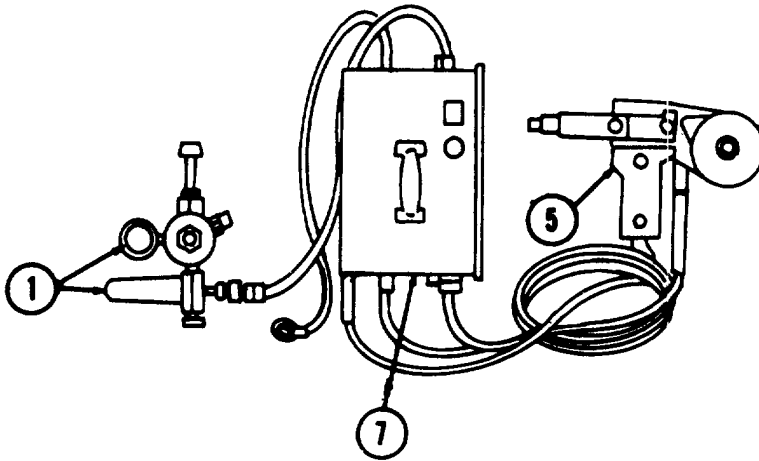

ITEM	LUBRICATE IN ACCORDANCE WITH CURRENT LUBRICATION ORDER	PAR REF
1	<u>ARGON GAS REGULATOR</u> , Inspect for leaks and improper operation.	33
5	<u>WELDING GUN</u> , Inspect for leaks and improper operation.	
7	<u>CONTROLS</u> , Inspect for damage. With the unit operating, inspect for improper operation.	
	<u>NOTE 1, OPERATION</u> , During operation, observe for any unusual noise or over-heating.	

MSC 3431-200-15/B.1

Figure 8. (Superseded Daily preventive maintenance services.

b. The item numbers are listed consecutively and indicate the sequence of minimum requirements. Refer to figure 8.1 for the quarterly preventive maintenance services.

Page 37, paragraph 67b, lines 4, 5 and 6. Delete "DA Form 464, Worksheet for Preventive Maintenance and Technical Inspection of Engineer Equipment", and substitute *DA Form 2404 (Equipment Inspection and Maintenance Worksheet)*.

Paragraph 69b, lines 4, 5 and 6. Delete "DA Form 464, Worksheet for Preventive Maintenance and Technical Inspection of Engineer Equipment" and substitute *DA Form 2404 (Equipment Inspection and Maintenance Worksheet)*.

Page 38, paragraph 70.

b. (Superseded) *Worksheet and Preventive Maintenance*. Applicable forms listed in TM 38-750 will be prepared for each major item of equipment when initially placed in limited storage, in accordance with the scheduled interval contained in AR 743-505. Perform required maintenance promptly to make sure equipment is mechanically sound and ready for immediate use.

c. (Added) *Operation*. Operate equipment in limited storage long enough to bring it up to operating temperature and insure complete lu-

brication of all bearings, gears, and the like, in accordance with the scheduled interval contained in AR 743-505. Equipment must be serviced and in satisfactory operating condition before it is operated.

72. Record and Report Forms (Superseded)

a. DA Form 2258 (Depreservation Guide of Engineer Equipment).

b. For other record and report **forms** applicable to field and depot. maintenance, refer to TM 38-750.

Note. Applicable forms, excluding Standard Form 46, which is carried by the operator, will be kept in a canvas bag mounted on the equipment.

Page 47, paragraph 3. After TM 5-505, add the following reference: TM 38-750, The Army Equipment Record System and Procedures.

4. Comments and Suggestions (Superseded)

Suggestions and recommendations for changes to the basic issue items list will be submitted on DA Form 2028 (Recommended Changes to DA Technical Manual Parts List or Supply Manual 7, 8 or 9) to the Commanding Officer, U. S. Army Mobility Support Center, ATTN : SMOMS-MS, P. O. Box 119, Columbus 16, Ohio, Direct communication is authorized

PREVENTIVE MAINTENANCE SERVICES

QUARTERLY

TM5-3431-200-15

WELDING SET

WESTINGHOUSE MODEL SA-135

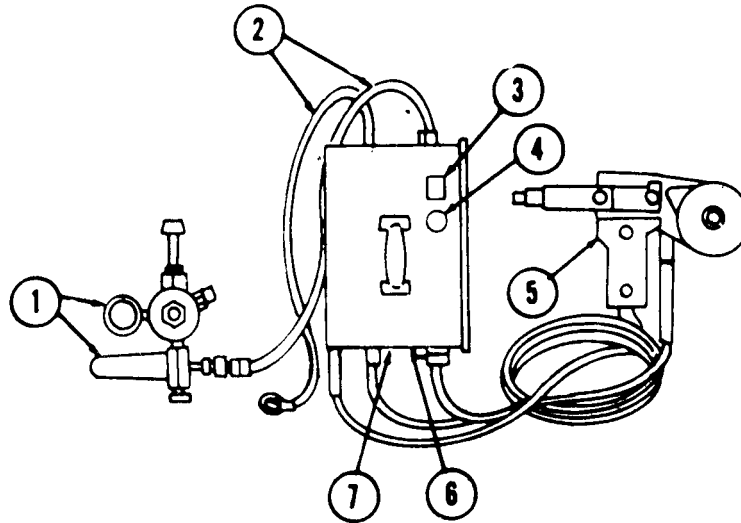

ITEM	LUBRICATE IN ACCORDANCE WITH CURRENT LUBRICATION ORDER	PAR REF
1	<u>ARGON GAS REGULATOR.</u> Inspect for cracks, leaks, and improper operation.	
2	<u>HOSE AND CABLE ASSEMBLIES.</u> Inspect for worn, frayed, and other damaged conditions. Inspect for loose connections on the hose and electrical cables.	
3	<u>CONTACTOR.</u> Inspect for defective wiring. Test the contactor for improper operation.	
4	<u>SOLENOID VALVE.</u> Inspect for leaks and loose electrical connections. Test for improper operation.	
5	<u>WELDING GUN.</u> Inspect for cracks, leaks, loose nose, and electrical connections; the nozzle, adapter, guide tube, gun tube, and gun barrel for weld spatter, and obstructions.	
6	<u>FUSE AND FUSE HOLDERS</u> Inspect for damaged holders, loose electrical connections, and for defective or missing fuses.	
7	<u>CONTROLS.</u> Inspect the controls for damage. With the unit operating, inspect for improper operation.	52

Figure 8.1. (Added) Quarterly preventive maintenance services.

ITEM		PAR REF
	<p><u>NOTE 1. OPERATIONAL TEST.</u> During operation, observe for any unusual noise or over-heating.</p>	
	<p><u>NOTE 2. ADJUSTMENTS.</u> Make all necessary adjustments during operational test,</p>	

MSC3431-200-15/8.2

TECHNICAL MANUAL

No. 5-3431-200-15

HEADQUARTERS,
DEPARTMENT OF THE ARMY
WASHINGTON 25, D. C., 29 August 1962

Operator, Organizational, Field, and Depot Maintenance Manual

WELDING SET, ARC, INERT GAS SHIELDED: PLASTIC OR METAL
LINED GUN; FOR 3/64-IN. WIRE; DC, 115-V (WESTINGHOUSE
MODEL SA-135) FSN 3431-879-9709

	<i>Paragraph</i>	<i>Page</i>
CHAPTER 1. INTRODUCTION		
Section I. General	1, 2	3
II. Description and data	3-5	3
CHAPTER 2. INSTALLATION AND OPERATION INSTRUCTIONS		
Section I. Service upon receipt of equipment	6-10	7
II. Movement to a new worksite	11,12	8
III. Controls and instruments	13,14	8
IV. Operation of equipment	15-24	10
CHAPTER 3. OPERATOR AND ORGANIZATIONAL MAINTENANCE INSTRUCTIONS		
Section I. Operator and organizational maintenance tools and equipment	25-27	13
II. Preventive maintenance services	28-31	13
III. Operator's maintenance	32-34	19
IV. Troubleshooting	35-44	21
V. Field expedient repairs	45-47	22
VI. Argon gas system	48,49	23
VII. Electrical system	50-60	25
VIII. Welding gun	61,62	32
CHAPTER 4. DEMOLITION OF WELDING SET TO PREVENT ENEMY USE	63-66	35
5. SHIPMENT AND LIMITED STORAGE		
Section I. Shipment within zone of interior	67,68	37
II. Limited storage	69,70	37
CHAPTER 6. FIELD AND DEPOT MAINTENANCE INSTRUCTIONS		
Section I. General	71,72	39
II. Description and data	73,74	39
III. Special tools and equipment	75-77	41
IV. Troubleshooting	78-84	41
V. Contactor maintenance instructions	85,86	42
VI. Gun handle assembly maintenance instructions	87,88	43,44
APPENDIX I. REFERENCES		47
II. MAINTENANCE ALLOCATION		49
III. BASIC ISSUE ITEMS		53
INDEX		57

CHAPTER 1

INTRODUCTION

Section I. GENERAL

1. Scope

a. These instructions are published for the use of the personnel to whom the Welding Set, Westinghouse Model SA-135, is issued. Chapters 1 through 5 provide information on the operation, daily preventive maintenance service, and organizational maintenance of the equipment, accessories, components, and attachments. Chapter 6 provides information for field and depot maintenance (3d, 4th, and 5th echelons). This manual also provides descriptions of the main units and their functions in relationship to other components.

b. Appendix I contains a list of publications applicable to this manual. Appendix II contains the Maintenance Allocation Chart. Appendix III contains the list of basic issue items authorized the operator of this equipment. The Organizational, Field, and Depot Maintenance Repair Parts and Special Tool Lists are listed in TM 5-3431-200-25P.

c. Numbers in parentheses on illustrations indicate quantity.

d. Report all deficiencies in this manual on DA Form 2028. Submit recommendations for changes, additions, or deletions to the Commanding Officer, U.S. Army Engineer Maintenance Center, ATTN: EMCDM-S, P. O. Box 119, Columbus 16, Ohio. Direct communication is authorized.

e. Report unsatisfactory equipment performance and suggestions for equipment improvement as specified in AR 750-5.

2. Record and Report Forms

For record and report forms applicable to the operator and organizational maintenance, refer to TM 5-505.

Note. Applicable forms, excluding Standard Form 46 which is carried by the operator, shall be kept in a canvas bag mounted on the equipment.

Section II. DESCRIPTION AND DATA

3. Description

a. *General.* The Westinghouse Welding Set, Model DA-135, (figs. 1 and 2) is designed for continuous duty, semiautomatic welding of aluminum, using a consumable aluminum wire electrode shielded by inert argon gas. The set is air cooled, rated at 200 amperes, and consists of a welding handgun, a control assembly with a built-in contactor, and an adjustable-pressure, constant flow argon gas regulator.

b. *Control Assembly.* The control assembly is a light weight, insulated metal box, containing gas pipe and electrical leads, gas solenoid

valve, contactor, rheostat, terminal strip, and the various relays, resistors, and capacitors necessary to assure proper welding operation. A toggle type power switch, line and motor fuses, and rheostat knob are located on the front of the control assembly. The control assembly also includes an argon gas hose and connection, a ground cable, a power supply cable, and a welding current cable. Connections for the welding gun cables are also located on the front of the control assembly.

c. *Welding Gun Assembly.* The welding gun assembly consists of the welding gun itself,

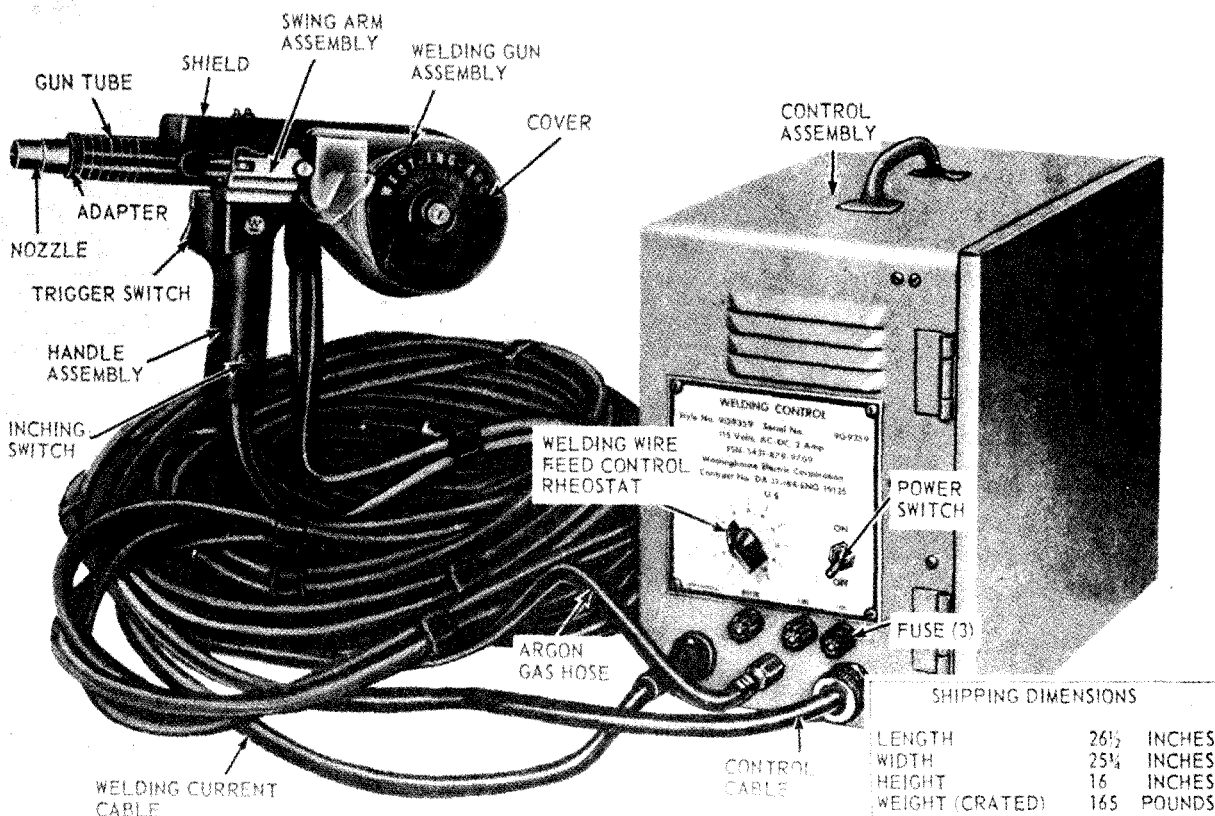

EMC 3431-200-15/1

Figure 1. Welding set, right front view, with shipping dimensions.

welding current cable, argon gas hose, and a control cable. The welding gun consists of the following: a handle assembly housing the welding wire drive motor, welding switch, inching switch, motor capacitor, and control cable connections; an electrically insulated aluminum shield with transparent plastic cover; a gun tube; an adapter and nozzle; and a mounting bracket and fitting assembly. The welding current cable and argon gas hose are connected to the mounting bracket.

4. Identification and Tabulated Data

a. Identification. The welding set has three identification plates.

- (1) *Corps of Engineers identification plate.* Located on the back of the control assembly. Specifies nomenclature, stock, and serial number, manu-

facturer, model and contract numbers, dimensions, and weight.

- (2) *Manufacturer's data plate.* Located on the front of the control assembly. Specifies nomenclature, style, serial, electrical ratings, Federal stock number, and contract number.
- (3) *Flowmeter manufacturer's data plate.* Located on the flowmeter body and specifies the manufacturer, model, capacity, and rate of flow range.

b. Tabulated Data.

- (1) *Corps of Engineers identification plate.*

Nomenclature	-----	Welding set, arc, insert gas shielded.
Stock No.	-----	3431-879-9709
Serial No.	-----	
Manufacturer	-----	Westinghouse Electric Corp.

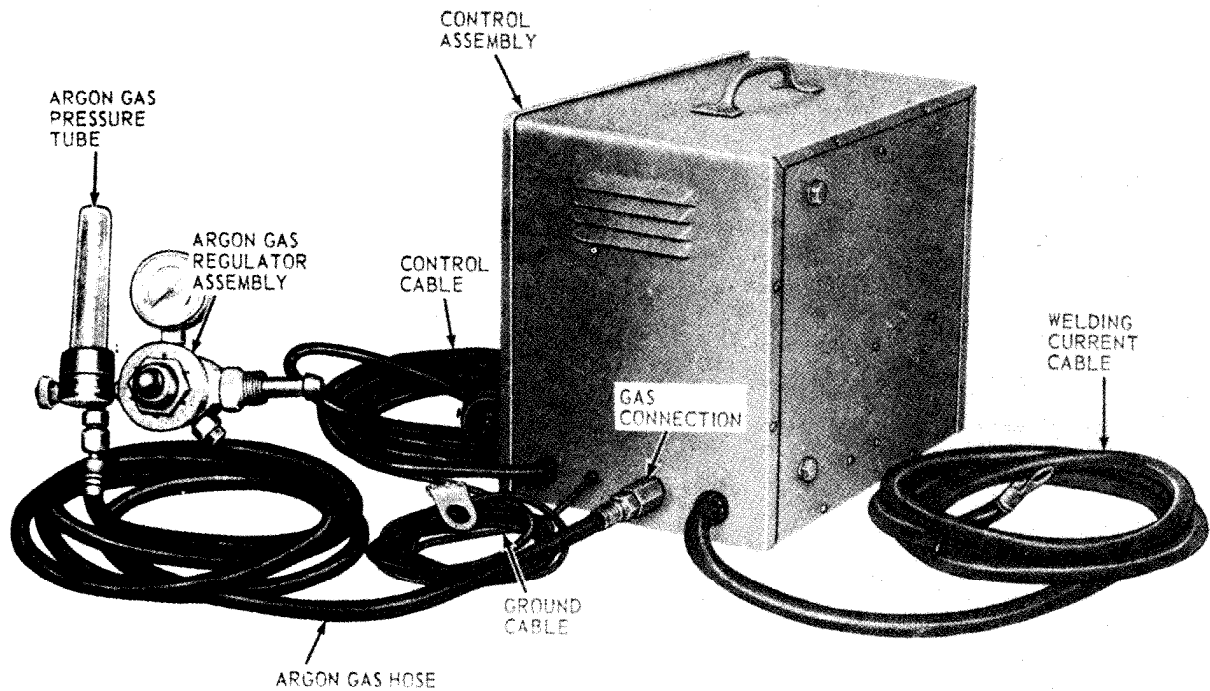

EMC 3431-200-15.2

Figure 2. Welding set, left rear, three-quarter view.

Model DA-135
 Contract No. DA 11-184-ENG-19125
 Length 26 1/2 in.
 Width 25 3/4 in.
 Height 16 in.
 Capacity
 G.V.W.
 Shipping wt. 165 lb
 Cubage 8.0 cu ft

(2) *Manufacturer's data plate.*

Manufacturer Westinghouse Electric Corp.
 Style No. 9G-9359
 Serial No.
 Voltage 115-v, ac-dc
 Amperes 2
 Federal Stock No. 3431-879-9709
 Contract No. DA 11-184-ENG-19125

(3) *Flowmeter manufacturer's data plate.*

Manufacturer Victor Equipment Co.
 Model V-0145
 Capacity (gage) 0-4000 lb
 Rate of flow 0-65 cfm

(4) *Control assembly.*

(a) *Contactor.*

Manufacturer Westinghouse Electric Corp.
 Type MM 410
 Style 552D 181 G02
 Amperes 200 dc (direct current)

(b) *Solenoid valve.*

Manufacturer Skinner Electric Valve Co.
 No. C21A 1061
 Voltage 115 v (volts) dc
 Watts 8
 Psi (pounds per square inch) 50
 Orifice 0.125 in. (inch)

(c) *Welding wire feed control rheostat.*

Manufacturer Ohmite Mfg. Co.
 Model HA
 Series A
 Insulation 300 v
 Watts 25
 Resistance 50 ohms

(d) Power switch.

Manufacturer -----Sargent Electric Corp.
Type -----SPDT, toggle
Amperes -----6, 12
Voltage -----125/250 v ac (alternating
current)-dc
Watts -----746

(5) Welding gun.

(a) Trigger switch relay capacitor.

Manufacturer -----Sprague Electric Co.
Type -----121 P
 μ f (microfarads) -----0.047
Voltage -----200 v dc

(b) Trigger switch.

Manufacturer -----Micro Switch Corp.
Type -----L4
Amperes -----5
Voltage -----250 v ac

(c) Inching switch.

Manufacturer -----Micro Switch Corp.
Type -----1PD3
Amperes -----5
Voltage -----250 v ac

(6) Argon gas regulator.

Manufacturer -----Victor Equipment Co.
Model -----V-0145
Capacity (gage) -----0-4000 psi
Rate of flow -----0-65 cfh (cubic feet per
hour)

(7) Dimensions and weight.

Length -----26 1/2 in.
Width -----25 3/4 in.
Height -----16 in.
Weight, crated -----165 lb (pounds)

(8) Wiring diagram. A practical wiring diagram of the welding set electrical system is shown in figure 3.

Figure 3. Practical wiring diagram.
(Located in back of manual)

5. Difference in Models

This manual covers only the Westinghouse Model SA-135 Welding Set. No known unit differences exist for the model covered by this manual.

CHAPTER 2

INSTALLATION AND OPERATION INSTRUCTIONS

Section I. SERVICE UPON RECEIPT OF EQUIPMENT

6. Unloading the Equipment

- a. Remove all blocking and tiedowns securing the welding set to the carrier,
- b. Two men or a forklift truck may be used to remove the welding set from the carrier.

Caution: Position the welding set on the forklift so that it will not tilt or slide off.

7. Unpacking the Equipment

Open the wooden crate and remove the gun and control assemblies. Be sure the boxes containing hose, aluminum wire, tools, fuses, adapter, gas nozzle, drive roll, guide tube, manuals case, and publications are included.

Caution: Use care in opening the crate and do not use hooks to lift the individual boxes.

8. Inspecting and Servicing Equipment

- a. Perform the before operation services (par. 29).
- b. Inspect the welding set for loss of parts or damage which might have occurred during shipment,
- c. Inspect the controls for loose or missing hardware.
- d. Inspect pipe, hose, and leads for insecure mounting, breaks, kinks, and other damage.
- e. Correct all deficiencies or report them to organizational maintenance.

9. Installation of Separately Packed Components

The regulator assembly and the reels of aluminum welding wire are packed separately.

For installation of the regulator assembly and aluminum wire refer to paragraph 10.

10. Installation or Setting Up Instructions

a. *Location.* Locate the control assembly as close to the work as possible so welding operations can be performed with a minimum of effort and adjustments in wire feed speed can be made quickly and easily. Approximately 50 feet of hose and cable are supplied with the gun, so locate the control assembly in such a manner that no kinks or sharp bends are made in the gas hose.

Caution: Do not drag hose or cable over hot work.

b. Connections.

- (1) *Gas.* Connect the argon gas regulator to a suitable source of argon gas, and connect the regulator to the control assembly with the 10-foot hose supplied. Tighten the gas connection (fig. 2).

(2) *Power.*

- (a) *Welding current cable.* Connect the welding current cable (fig. 2) to the positive terminal of the welder.
- (b) *Control cable.* Connect the 10-foot, 3-wire, control cable (fig. 2) into a welder auxiliary power supply only, to provide the 115 volts necessary to operate the control assembly.
- (c) *Ground cable.* Connect the 10-foot ground cable (fig. 2) to the negative terminal of the welder.

c. *Loading the Welding Gun.* The welding gun will use approximately 8 reels of consumable wire electrode in a day. Refer to figure 4 and load the gun.

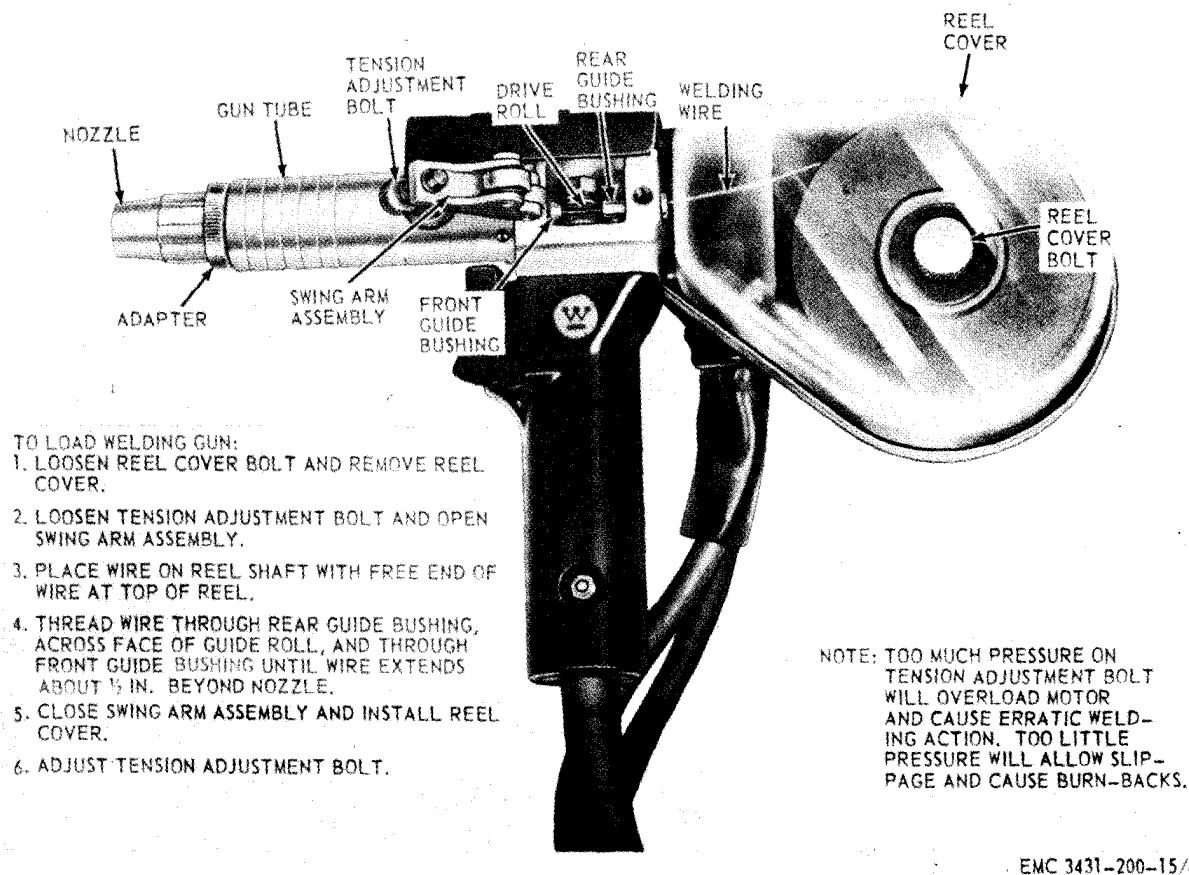

EMC 3431-200-15/4

Figure 4. Welding gun, loading instructions.

Section II. MOVEMENT TO A NEW WORKSITE

11. Dismantling for Movement

a. Disconnect the welding current cable, control power cable, and ground cable from the welder.

b. Disconnect the argon gas regulator from the source of supply.

c. The welding set can be hand carried or transported by hand truck to a new worksite.

12. Reinstallation After Movement

Install the welding set at the new worksite as instructed in paragraph 10.

Section III. CONTROLS AND INSTRUMENTS

13. General

This section describes, locates, illustrates, and furnishes the operator or organizational maintenance personnel sufficient information about the various controls and instruments for proper operation of the welding set.

14. Controls and Instruments

The purpose and location of all controls and instruments are shown in figure 5.

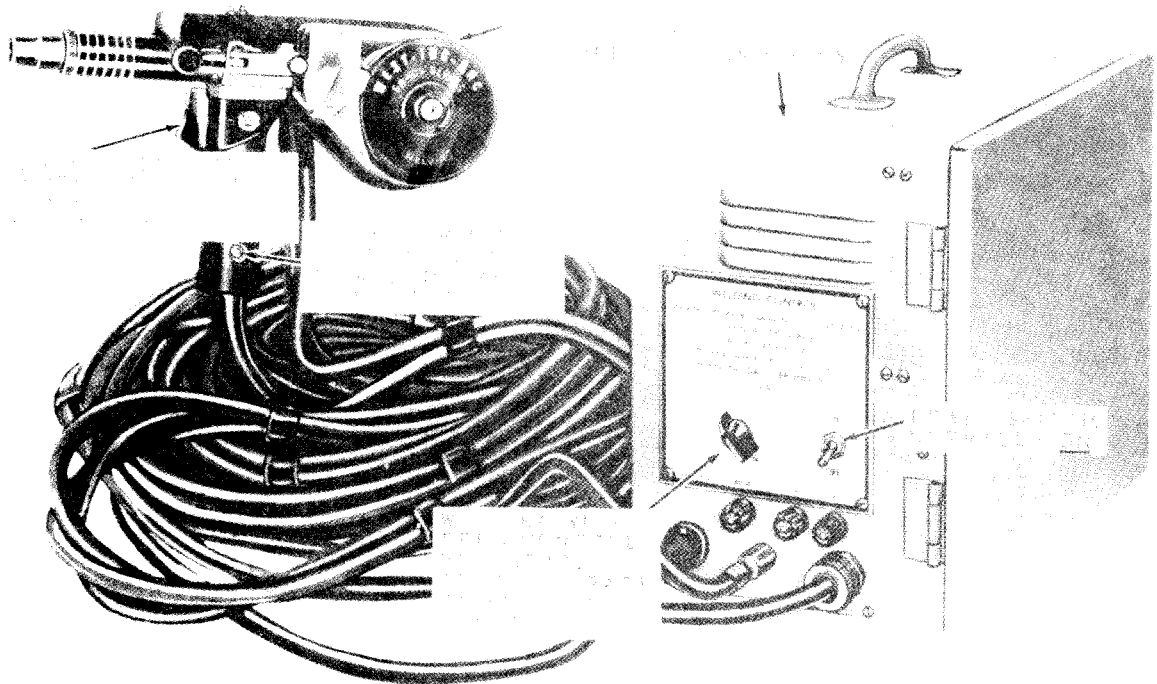

2. ACCESSORIES TO WATER ASSEMBLY

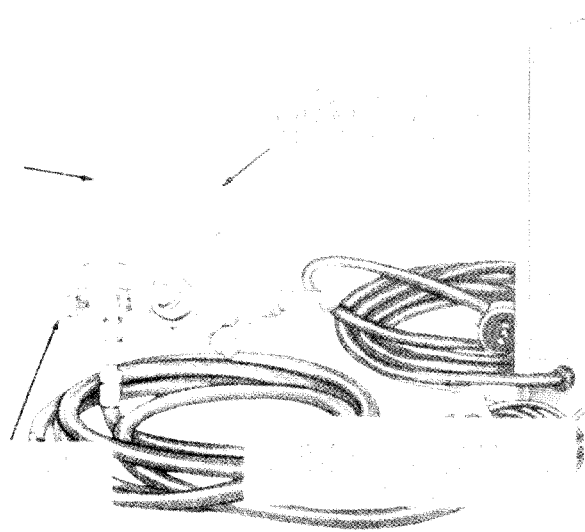

3. ACCESSORIES TO WATER ASSEMBLY

Figure 5. Controls and instruments.

Section IV. OPERATION OF EQUIPMENT

15. General

a. The instructions in this section are published for the information and guidance of the personnel responsible for operation of the welding set.

b. The operator must know how to perform every operation of which the welding set is capable. This section gives instructions on starting and stopping the welding set, basic functions of the welding set, and on coordinating the basic functions to perform the specific tasks for which the equipment is designed. Since nearly every job presents a different problem, the operator may have to vary given procedures to fit the individual job.

16. Starting the Welding Set

a. Preparation for Starting. Perform the before-operation services (par. 29).

b. Starting. Refer to figure 6 and start the welding set.

17. Stopping the Welding Set

a. Refer to figure 7 and stop the welding set.

b. Refer to paragraph 29 and perform the after-operation services.

18. Welding Set Operation

Refer to figure 6 for welding set operation instructions,

19. Operation in Extreme Cold (Below 0° F.)

Inspect the cables, gas hose, and plastic parts of the welding set more frequently during cold weather operation than during normal operation. Check for brittleness of insulation, and hardening of the gas hose which may affect gas flow.

Caution: Exercise caution when working with hoses or cables in extreme cold, hoses and cable insulation become brittle and will crack and break with excessive handling.

20. Operation in Extreme Heat

Although the welding set is air cooled, provide for adequate ventilation if it is used indoors in high ambient temperatures.

21. Operation in Dusty or Sandy Areas

a. Shield the welding set as much as possible from blowing sand or dust during operation.

b. Inspect the nylon guide bushings, guide tube, and gas ports for clogging sand or dust. Obstructing sand or dust will cause improper wire feed and/or insufficient gas flow.

c. Provide adequate protective covering for the set when not in use.

22. Operation Under Rainy or Humid Conditions

a. If it is necessary to weld in the rain, protect the work and the welding set as much as possible from the elements.

b. Wipe all exposed surfaces frequently,
c. Paint chipped or scratched surfaces to prevent rust,

d. If the welding set is outside and not in use, protect it with a canvas or other waterproof covering. Remove the cover during dry periods. Open the door of the control assembly to allow the electrical components to dry before operating.

23. Operation in Salt Water Areas

a. Exposed, bare metal will corrode more rapidly in salt water areas than in other areas. Wipe the welding set with a cloth dampened in fresh water and dry thoroughly,

b. Coat exposed metal surfaces with an approved rustproofing material. Remove rust immediately and paint or apply oil as needed.

c. Check electrical cables for salt water damage and remove corrosion from electrical leads and contacts.

24. Operation at High Altitudes

High altitudes will not affect the operating efficiency of the welding set.

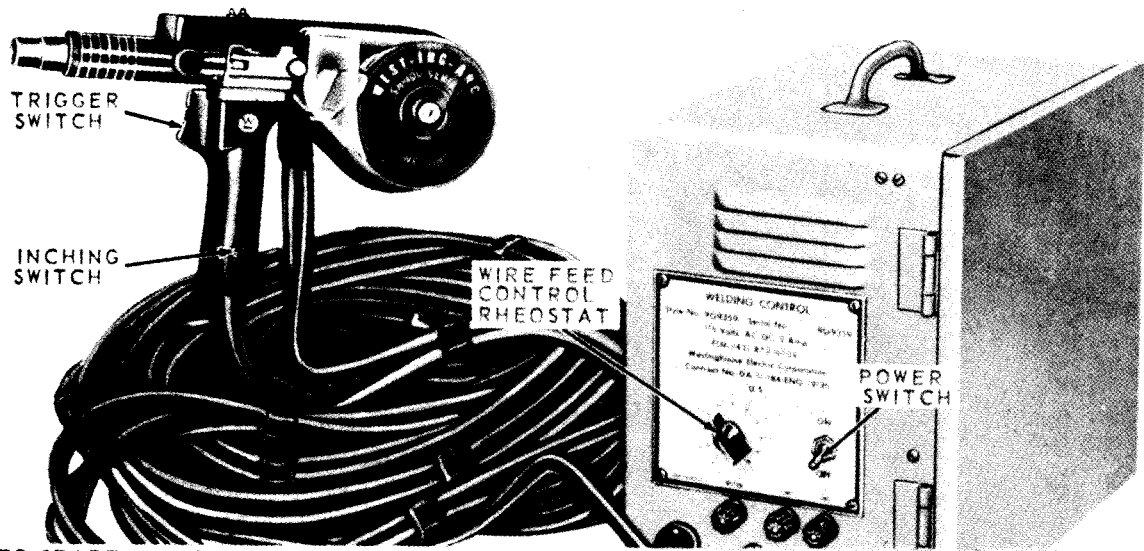

TO START AND OPERATE WELDING SET:

1. PLACE POWER SWITCH IN ON POSITION.
2. PRESS INCHING SWITCH UNTIL WELDING WIRE PROTRUDES ABOUT $\frac{1}{8}$ -INCH BEYOND NOZZLE, THEN RELEASE.
3. TURN WIRE FEED CONTROL RHEOSTAT TO MAXIMUM SETTING.

NOTE: THE MAXIMUM SETTING OF THE WIRE FEED CONTROL RHEOSTAT MAY PRODUCE TOO SHORT AN ARC AND CAUSE THE WELDING WIRE TO STUB. ADJUST THE RHEOSTAT UNTIL PROPER ARC LENGTH IS OBTAINED. THIS USUALLY OCCURS WHEN THE CRACKLING SOUND OF THE ARC CAN NO LONGER BE HEARD.

A. WELDING GUN AND CONTROL UNIT.

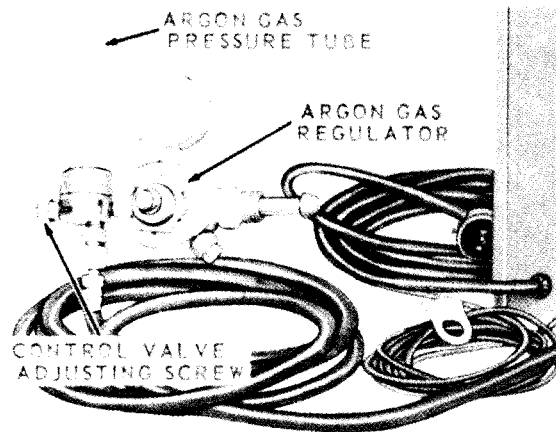

1. PRESS TRIGGER SWITCH AND ADJUST ARGON GAS FLOW TO 35 CFH AS INDICATED BY PRESSURE TUBE. RELEASE TRIGGER SWITCH.
2. PRESS TRIGGER SWITCH AND BRING WIRE INTO CONTACT WITH WORK. AN ARC WILL FORM AND THE WIRE WILL FEED.

B. ARGON GAS REGULATOR AND PRESSURE TUBE.

Figure 6. Welding set, starting and operating instructions.

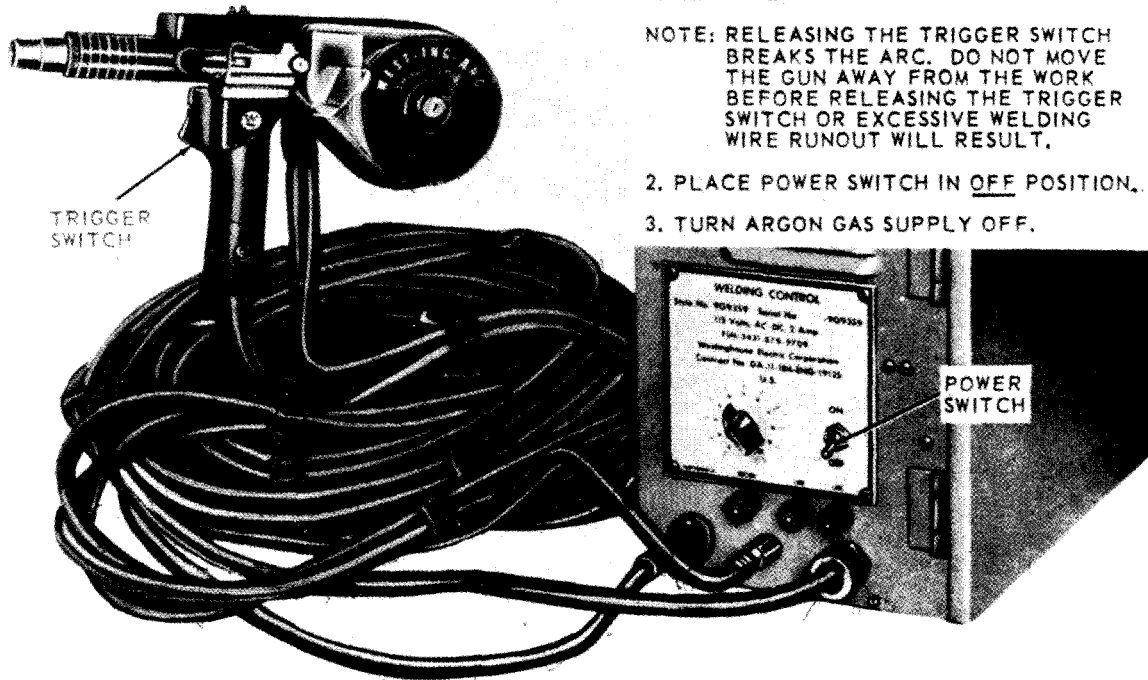

TO STOP WELDING:

1. RELEASE TRIGGER SWITCH.

NOTE: RELEASING THE TRIGGER SWITCH BREAKS THE ARC. DO NOT MOVE THE GUN AWAY FROM THE WORK BEFORE RELEASING THE TRIGGER SWITCH OR EXCESSIVE WELDING WIRE RUNOUT WILL RESULT.

2. PLACE POWER SWITCH IN OFF POSITION.
3. TURN ARGON GAS SUPPLY OFF.

EMC 3431-200-15/7

Figure 7. Welding set, stopping instructions.

CHAPTER 3

OPERATOR AND ORGANIZATIONAL MAINTENANCE INSTRUCTIONS

Section I. OPERATOR AND ORGANIZATIONAL MAINTENANCE TOOLS AND EQUIPMENT

25. Special Tools and Equipment

No special tools or equipment are required by the operator or organizational maintenance personnel for the maintenance of this welding set.

26. Basic Issue Tools and Equipment

Tools and repair parts issued with or author-

ized for the welding set are listed in the Basic Issue Items List, Appendix III.

27. Organizational Maintenance Repair Parts

Organizational maintenance repair parts are listed and illustrated in TM 5-3431-200-25P.

Section II. PREVENTIVE MAINTENANCE SERVICES

28. General

To insure that the equipment is ready for operation at all times, it must be inspected systematically before operation, during operation, and after operation, so that defects may be discovered and corrected before they result in serious damage or failure. The necessary preventive maintenance services shall be performed before operation. Defects discovered during operation of the unit shall be noted for future correction, to be made as soon as operation has ceased. Stop operation immediately if a deficiency is noticed during operation which would damage the equipment if operation were continued. After-operation services shall be performed by the operator after every operating period. After-operation service shall be performed at intervals based on the normal operation of the equipment. Reduce interval to compensate for abnormal conditions. Defects or unsatisfactory operating characteristics beyond the scope of the operator to correct must be re-

ported at the earliest opportunity to organizational maintenance. Responsibility for performance of preventive maintenance service rests not only with the operator but also with the entire chain of command from section chief to commanding officer (AR 750-5).

29. Operator's Daily Services

a. General. The intervals at which specific daily services are to be performed by the operator are indicated by an X in the appropriate column in figure 8 as follows:

B-Before operation
D-During operation
A-After operation

b. Additional Daily Services (Not Illustrated). An X in the appropriate column(s) indicates the interval at which the service is to be performed.

WELDING GUN

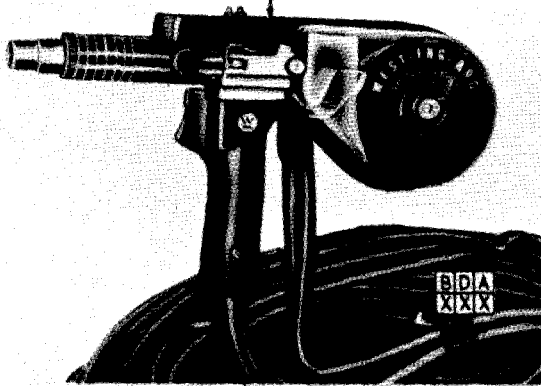

WELDING GUN

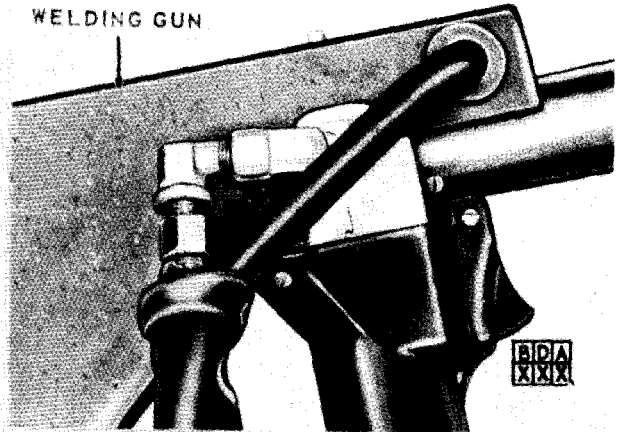

A. INSPECT WELDING GUN FOR LOOSE AND MISSING HARDWARE, DAMAGED COVER, AND FOR BURNED OR CLOGGED NOZZLE.

B. INSPECT WELDING GUN FOR LOOSE OR DAMAGED GAS AND ELECTRICAL CONNECTIONS AND FOR MISALIGNED SHIELD.

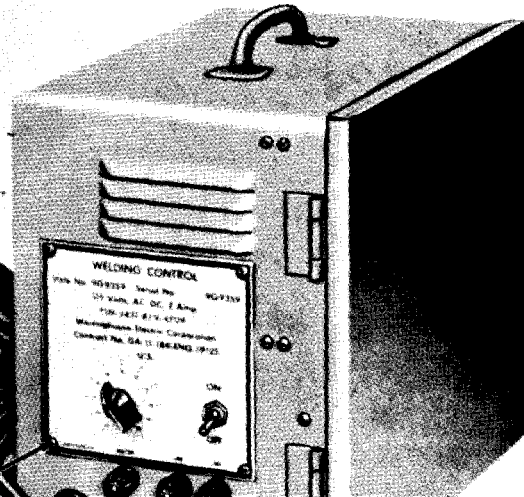
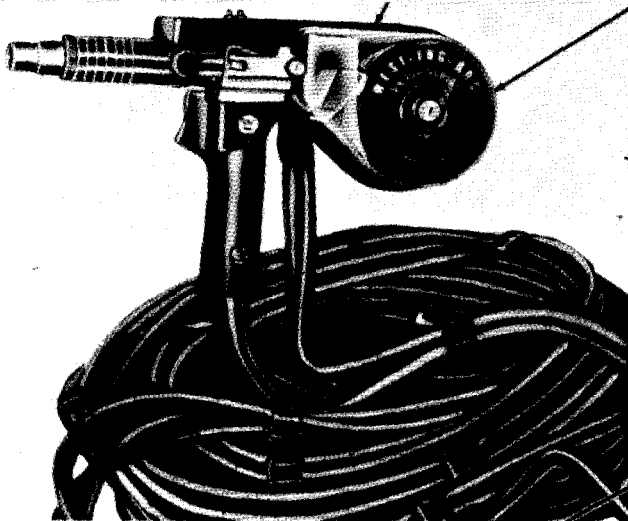

C. INSPECT CONTROL UNIT FOR LOOSE OR MISSING HARDWARE AND FOR LOOSE OR DAMAGED GAS AND ELECTRICAL CONNECTIONS.

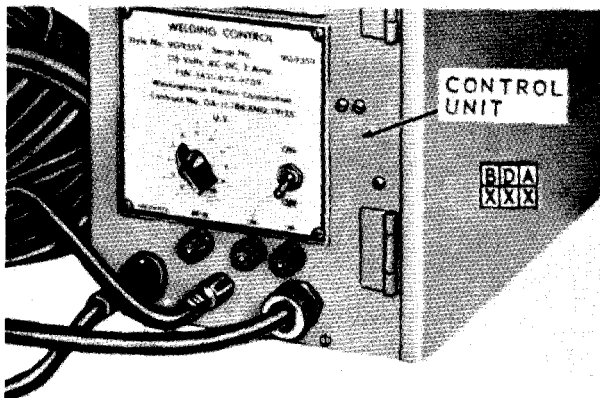

NOTE: CORRECT OR REPORT DEFICIENCIES TO ORGANIZATIONAL MAINTENANCE.

Figure 8. Operator's daily services.

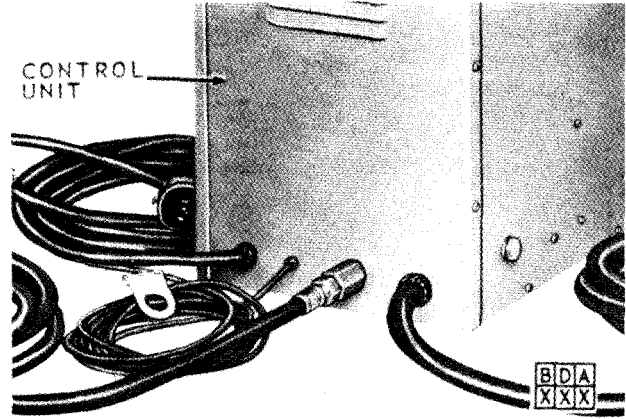
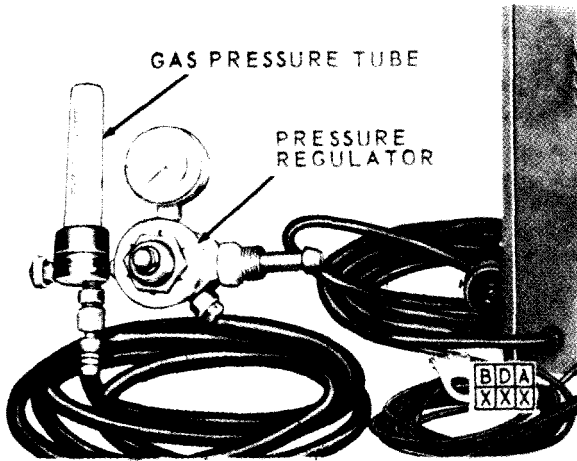

D. INSPECT PRESSURE REGULATOR, GAS PRESSURE TUBE, AND DIAL GLASS FOR CRACKS AND BREAKS AND FOR LEGIBILITY OF MARKINGS.

E. INSPECT THE CONTROL UNIT FOR LOOSE OR MISSING HARDWARE AND FOR LOOSE OR DAMAGED GAS AND ELECTRICAL CONNECTIONS.

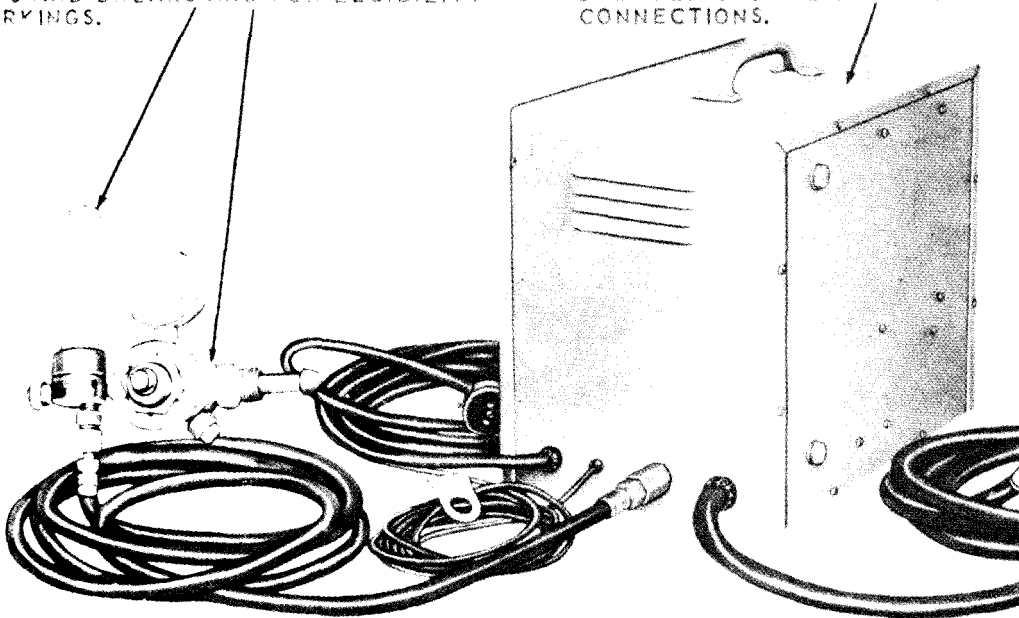

NOTE: CORRECT OR REPORT DEFICIENCIES TO ORGANIZATIONAL MAINTENANCE.

TM 5-3431-200-1578 (2)

Figure 8 - Continued.

B	Intervals		Procedure
	D	A	
X	X	X	<i>Leaks, general.</i> Inspect the gas pipe and hose connections for leaks. Correct any leakage noticed or report it to organizational maintenance.
X	X	X	Visual inspection. Inspect the entire welding set for obvious deficiencies, breaks in leads, loose or missing

B	Intervals		Procedure
	D	A	
			hardware, insecure controls or <i>components</i> , and any other damage which might have occurred since the last inspection. Correct all deficiencies or report deficiencies beyond the scope of the operator to organizational maintenance.

Intervals			Procedure
B	D	A	
X	--	X	<i>Cleanliness.</i> Inspect the entire welding set for dirt. Clean dirty surfaces with an approved solvent, dry thoroughly. Inspect the gas ports in the gun barrel and remove all obstructions (par. 62).
X	--	X	<i>Publications.</i> Make sure that a copy of this manual and DA Form 285 are on, or with the welding set and are in serviceable condition.
X	--	--	<i>Unusual operation and noises.</i> Investigate abnormal operation; erratic wire feed, unusual motor noise, smoking, and failure to respond to controls. Shut off the welding set if irregularities are noticed and correct the condition. If the condition is beyond the scope of the operator, report the condition to organizational maintenance.
X	--	X	<i>Tools.</i> Inspect the tools and equipment assigned to the welding set; be sure they are in good condition, clean and properly stowed.
X	X	X	<i>Protection.</i> Protect the welding set from tampering, damage, and misuse. Do not use the control assembly for a step or a seat. Keep cables and hose free from kinks and sharp bends. Cover the welding set when it is not in use. If not used for a prolonged period of time, coat unpainted metal parts with an approved rust inhibitor.

30. Organizational Maintenance

a. Preventive maintenance is performed by organizational maintenance personnel at quarterly intervals. A quarterly interval is equivalent to 3 calendar months, or 250 hours of operation, whichever occurs first.

b. The preventive maintenance services to be performed at quarterly intervals are listed consecutively (starting with No. 1) and are described in paragraph 34. The service refers to a preventive maintenance services "Title" on DA Form 464 and indicates the services to be performed. The number listed under "Inspection" indicates the minimum inspection requirements for the equipment.

31. Quarterly Preventive Maintenance Services

Inspection	Service Quarterly	GENERAL
1	1	BEFORE-OPERATION SERVICES. Inspect the welding set and perform the services listed in daily before-operation services (par. 29).
2	2	TOOLS AND EQUIPMENT. Inspect the condition of the tools assigned to the welding set. Inspect the condition of the canvas case. Be sure tools assigned to the welding set are clean, serviceable, and properly stowed. Be sure the canvas case closes and fastens properly.
3	3	PUBLICATIONS. Be sure a copy of this manual, TM 5-3431-200-15, TM 5-3431-200-25P, and DA Form 285 are on or with the welding set and are in serviceable condition.
4	4	APPEARANCE. Inspect the general appearance of the welding set (figs. 1 and 2). Pay special attention to dirt, illegibility of identification markings, and the condition of the paint. Correct deficiencies or report them to field maintenance.
5	5	MODIFICATION. Be sure that all available modification work orders applying to the welding set have been completed and recorded on DA Form 478, DA Form 5-73, and DA 5-73a as applicable.
6	6	CONTROL ASSEMBLY GAS HOSE ASSEMBLIES. Inspect the gas hose assemblies for loose or damaged mounting hardware, damaged ferrules, cracked or broken hose and stripped nipples. Tighten loose mounting hardware. Replace hose assemblies having defective parts (par. 49).
7	7	SOLENOID VALVE AND GAS PIPE. Inspect the solenoid valve and gas pipe for loose or missing mounting hardware, loose electrical connections, and defects. Tighten loose hardware and connections; replace missing hardware; straighten a bent pipe; test the solenoid valve (par. 49), and replace a defective solenoid valve and pipe (par. 49).

Inspection	Service Quarterly	
8	8	<p>(CABLES ASSEMBLIES, STRAIN RELIEFS, AND TERMINAL STRIP.</p> <p>Inspect the cable assemblies for loose connections, cracks, and breaks, inspect the strain reliefs for slippage and missing parts. Inspect the terminal strip for loose or missing mounting hardware, loose or missing terminals, breaks, and cracks.</p>
	8	<p>Tighten loose cable connections and replace defective cables (par. 51). Tighten loose strain reliefs or replace damaged or defective strain reliefs (par. 51). Tighten loose terminal strip hardware or replace missing hardware (par. 51). Replace a defective terminal strip (par. 51).</p>
9	9	<p>RHEOSTAT, RESISTOR, AND FUSE HOLDERS.</p> <p>Inspect the rheostat and knob for loose or missing mounting hardware or loose electrical connections, and for defects. Inspect the resistor for loose or missing connections and for damage. Inspect the fuse holders for loose mounting and broken electrical connections and for damage.</p>
	9	<p>Tighten loose hardware and connections. Replace missing connections (par. 52). Test the rheostat (par. 52). Replace a defective rheostat or knob (par. 52). Tighten or solder loose resistor connections. Test the resistor (par. 52) and replace a defective resistor (par. 52) Tighten loosely mounted fuse holders, solder broken electrical connections, and replace a defective fuse holder (par. 52).</p>
10	10	<p>CONTACTOR. Inspect the contactor for loose or missing mounting hardware, loose electrical connections, anti for damaged or defective parts.</p>
	10	<p>Tighten loose hardware and connections. Replace missing hardware. Test the contactor (par. 53). Replace a defective cantactor (par. 53).</p>

Inspection	Service Quarterly	
11	11	<p>CURRENT RELAY, CURRENT RELAY CAPACITOR, AND RECEPTACLE.</p> <p>Inspect the relay for loose or missing mounting hardware, loose electrical connections, and for damage or defects. Inspect the capacitor for loose mounting, loose or broken electrical connections, and for defects. Inspect the receptacle for loose mounting and for defects.</p>
	11	<p>Tighten loose relay hardware and electrical connections; replace missing hardware. Test the relay (par. 54). Replace a defective relay (par. 54). Tighten loose capacitor hardware. Tighten or resolder loose electrical connections. Test the capacitor (par. 54). Replace a defective capacitor (par. 54). Tighten a loose receptacle. Replace a defective receptacle (par. 54).</p>
12	12	<p>CONTROL PANEL</p> <p>RECTIFIER. Inspect the rectifier for loose or missing mounting hardware, unsolderd connections, and defects.</p>
	12	<p>Tighten loose or replace missing mounting hardware. Solder loose connections. Test the rectifier (par. 56). Replace a defective rectifier (par. 56).</p>
13	13	<p>INCHING FEED RESISTOR, INCHING SPEED RESISTOR, AND CONTACTOR RESISTOR.</p> <p>Inspect the resistors for loose or missing mounting hardware, broken electrical connections, and other damage.</p>
	13	<p>Tighten loose or replace missing mounting hardware. Solder broken electrical connections. Test the resistors (par. 59). Replace defective resistors (par. 59).</p>
14	14	<p>TRIGGER SWITCH RELAY CAPACITOR, INCHING SWITCH RELAY CAPACITOR AND RECTIFIER FILTER CAPACITOR.</p> <p>Inspect the capacitors for broken electrical connections and damage</p>
	14	<p>Solder broken electrical connections. Test the capacitors (par. 60). Replace defective capacitors (par. 60).</p>

Inspection	Service Quarterly	
15	15	TRIGGER SWITCH AND INCHING SWITCH RELAYS. Inspect the relays for loose or missing mounting hardware, loose or broken electrical connections, and damage or defects.
	15	Tighten loose or replace missing mounting hardware. Connect loose or solder broken electrical connections. Test the relays (pars. 57 and 58). Replace a defective relay (pars. 57 and 58).
		WELDING GUN
16	16	COVER, SHIELD, AND CURRENT CABLE. Inspect the cover for loose or missing mounting hardware, bent condition, and other defects. Inspect the shield for loose or damaged mounting screw, cracks, or breaks, inspect the current cable for cracks, breaks, and loose connections.
	16	Tighten loose or replace missing cover mounting hardware. Replace or repair a defective cover (par. 61). Tighten loose or replace a damaged shield mounting screw (par. 61). Replace or repair a defective shield (par. 61). Tighten loose current cable connections or replace a damaged cable (par. 61).
17	17	HANDLE ASSEMBLY AND CONTROL CABLE. Inspect the handle assembly for loose or missing hardware and damage. Inspect the control cable for loose connection and damage.
	17	Tighten loose or replace missing mounting hardware. Report a defective handle assembly to field maintenance. Report a loose or damaged control cable to field maintenance.
18	18	DRIVE ROLL AND GUIDE BUSHINGS. Inspect the drive roll for loose mounting and dirty serrations. Inspect the guide bushings for loose mounting and excessive wear.
	18	Tighten a loose drive roll. Service the drive roll (par. 33). Report defective drive roll or guide bushings to field maintenance.

Inspection	Service Quarterly	
19	19	SWING ARM ASSEMBLY AND FITTING ASSEMBLY. Inspect the swing arm assembly for loose mounting, missing hardware, damaged idler roll, broken spring, and other damage. Inspect the fitting assembly for loose connections and damage.
	19	Tighten loose or replace missing swing arm hardware. Replace defective swing arm parts (par. 61). Tighten a loose fitting assembly. Solder as necessary (par. 61). Replace a defective fitting assembly (par. 61).
	20	NOZZLE, ADAPTER, AND GUIDE TUBE. Inspect the nozzle and adapter for loose connection, burned tip, and other damage. Inspect the guide tube for short length, bent condition, and other damage.
	20	Tighten a loose adapter. Service the nozzle (par. 33). Replace a damaged nozzle (par. 62). Replace a defective guide tube (par. 62). Service the guide tube (par. 33).
	21	GUN TUBE AND INSULATION. Inspect the gun tube for loose or missing hardware, breaks, or other damage. Inspect the insulation for cracks, breaks, and other damage.
	21	Tighten a loose gun tube. Replace missing hardware. Replace a defective gun tube (par. 62). Replace defective insulation (par. 62).
	22	ARGON GAS REGULATOR. Inspect the argon gas pressure tube cup for insecure mounting, breaks, and other damage. Inspect the pressure tube for improper seating, breaks, and other damage. Inspect the regulator for other obvious defects and damage.
	22	Mount the argon gas pressure tube cup securely or replace a damaged cup (par. 34). Seat the pressure tube properly or replace a damaged tube (par. 34). Adjust the regulator (par. 34). Replace a damaged regulator (par. 34).

Section III. OPERATOR'S MAINTENANCE

32. Fuse Replacement

a. Removal.

- (1) Refer to figure 1 for fuse location.
- (2) Turn each fuse cap 1/4 turn counter-clockwise to remove, then remove fuse from cap.

b. Cleaning and Inspection.

- (1) Clean with a dry cloth.
- (2) Inspect fuses for cracked or broken glass envelope. Replace fuse if damaged.

c. Installation. Reverse the procedure of a above and install the fuses.

33. Welding Gun Service

Refer to figure 9 and service the welding gun.

34. Argon Gas Regulator

a. Adjustment. Refer to figure 10 and adjust the argon gas regulator.

b. Removal. Refer to figure 10 and remove the argon gas regulator.

c. Cleaning and Inspection.

- (1) Clean the argon gas regulator with a dry, lint-free cloth, or with dry compressed air.
- (2) Inspect for leaks, cracked or broken glass, worn or stripped threads, and improper operation. Replace the regulator if it is damaged or defective.

d. Installation. Refer to figure 10 and install the argon gas regulator.

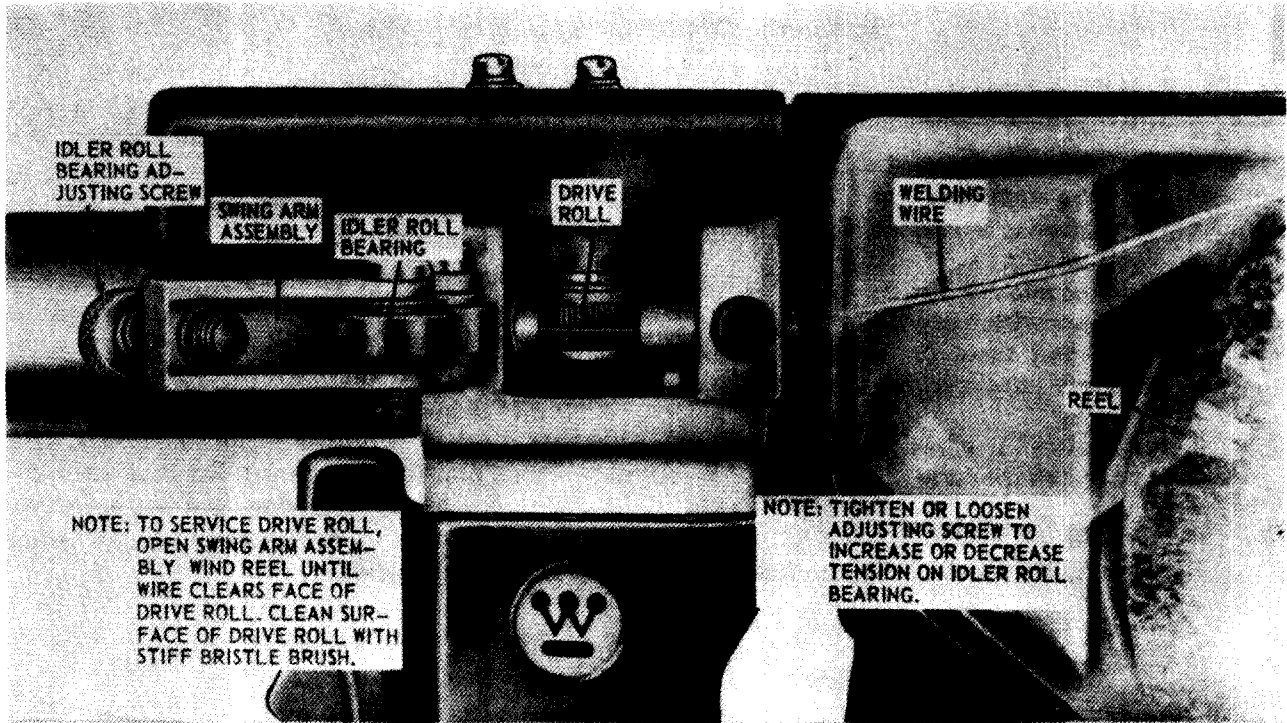

A. DRIVE ROLL.

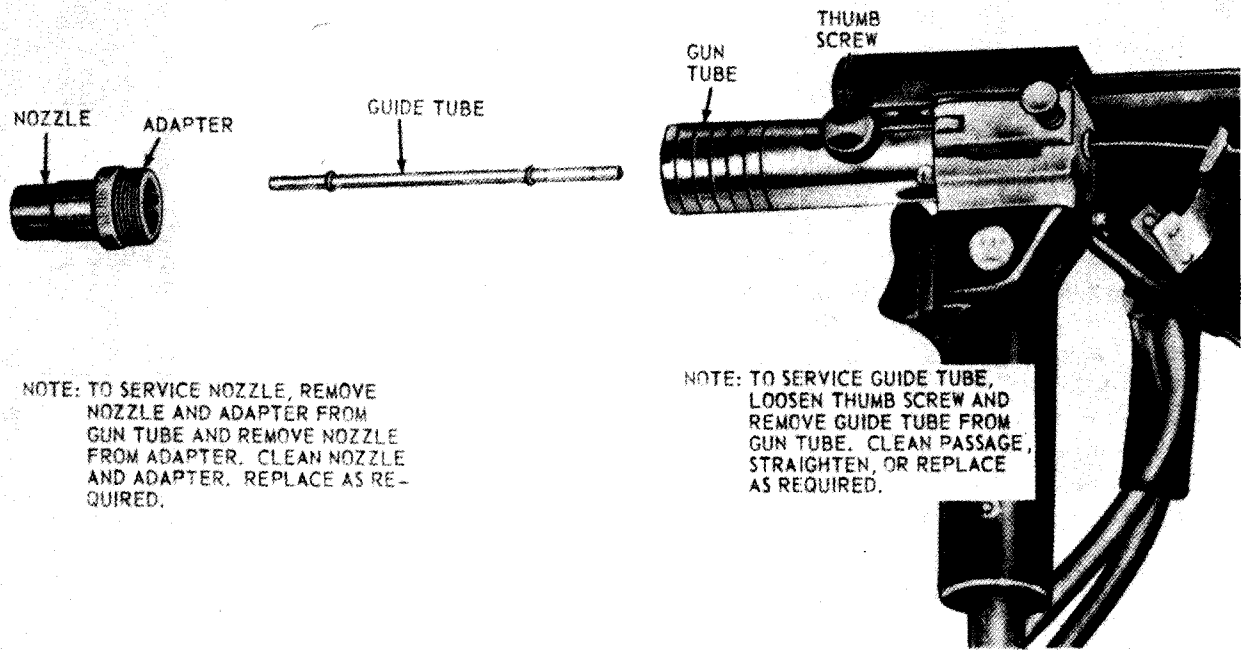

B. NOZZLE AND GUIDE TUBE.

Figure 9. Welding gun, service.

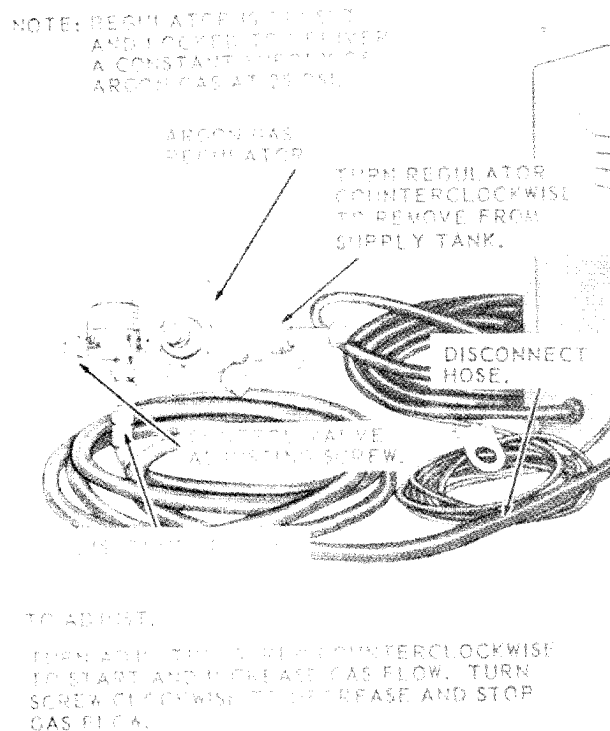

TM 5-3431-200-15 10

Figure 10. Argon gas regulator, adjustment, removal and installation.

Section IV. TROUBLESHOOTING

35. General

This section provides information useful in diagnosing and correcting unsatisfactory operation or failure of the welding set and its components. Each trouble symptom stated is followed by a list of the probable causes of the trouble. The possible remedy recommended is described opposite the probable cause. Any trouble beyond the scope of organizational maintenance shall be reported to field maintenance, 3d echelon.

36. Welding Set Will Not Start or Weld

<i>Probable cause</i>	<i>Possible remedy</i>
Welding set not connected to welder.	Connect the welding set to the welder (par. 10).
Power switch not in ON position,	Place the switch in the ON position

<i>Probable cause</i>	<i>Possible remedy</i>
Fuse defective -----	Replace the fuse (par. 32).
Rheostat not adjusted properly.	Adjust the rheostat (par. 16).

37. Wire Will Not Feed

<i>Probable cause</i>	<i>Possible remedy</i>
Motor fuse blown -----	Replace the fuse (par. 32).
Drive roll dirty or worn----	Service the drive roll (par. 33). Report defective roll to field maintenance.
Idler roll bearing tension too great.	Adjust the idler roll bearing tension (par. 33).
Guide bushings clogged or defective.	Clean the guide bushings or replace defective bushings.
Guide tube bent or defective.	Service the guide tube (par. 33), or replace a defective guide tube (par. 62).

38. Argon Gas Will Not Flow

<i>Probable cause</i>	<i>Possible remedy</i>
Argon gas cylinder valve not open.	Open the argon gas cylinder valve.
Argon gas regulator not adjusted or defective.	Adjust the argon gas regulator (par. 34) or replace a defective gas regulator (par. 34).
Gas pipe or solenoid valve defective.	Replace defective pipe (par. 49) or solenoid valve (par. 49).
Gas hose or fittings defective.	Replace defective hose (par. 49), or fittings (par. 49).
Gun barrel ports clogged.	Clean the gun barrel ports (par. 62).
Fitting assembly defective.	Replace the fitting assembly (par. 61).

39. Welding Gun Shorts Between Nozzle and Guide Tube

<i>Probable cause</i>	<i>Possible remedy</i>
Spatter between nozzle and guide tube.	Remove spatter with a file or scraper.
Wire feed too slow -----	Adjust the wire feed speed (par. 16).
Motor fuse blown -----	Replace the motor fuse (par. 32).
Control assembly ground cable not connected to negative terminal of the welder.	Connect the control assembly ground cable to the negative terminal of the welder (par. 10).
Wire stops feeding - - - - -	Adjust tension of idler roller (par. 33) or clean drive roll (par. 33).

40. Wire Feed Speed Too Slow

<i>Probable cause</i>	<i>Possible remedy</i>
Rheostat not properly adjusted.	Adjust rheostat until wire feed speed is correct (par. 16).
Idler roll tension too great _.	Adjust the tension of the idler roll (par. 33).
Wire drive roll dirty or damaged.	Service the drive roll (par. 33).

41. Wire Feed Speed Too Fast

<i>Probable cause</i>	<i>Possible remedy</i>
Rheostat not properly adjusted.	Adjust the rheostat until wire speed is correct (par. 16).

<i>Probable cause</i>	<i>Possible remedy</i>
Idler roll tension too weak.	Adjust the tension of the idler roll (par. 33).

42. Argon Gas Leaks

<i>Probable cause</i>	<i>Possible remedy</i>
Gas connections loose or defective or hose defective.	Tighten the gas connections (par. 10) or replace hose (par. 49).
Solenoid valve defective-----	Replace the solenoid valve (par. 49).
Front guide bushing worn or defective.	Replace the front guide bushing.
Argon gas regulator defective.	Replace the argon gas regulator (par. 34).

43. Argon Gas Flow Obstructed

<i>Probable cause</i>	<i>Possible remedy</i>
Solenoid valve defective ---	Replace the valve (par. 49).
Gas hose pinched or bent.	Correct condition and straighten hose (par. 10).
Gun barrel ports clogged or defective.	Clean the ports or replace the barrel (par. 62).

44. Welding Set Starts but Fails to Keep Welding

<i>Probable cause</i>	<i>Possible remedy</i>
Wire spool empty -----	bad gun with a full spool (par. 10).
Contacting failure -----	Replace the contactor (par. 53).
Fuses defective ___-___ ---	Replace fuses (par. 32).
Rheostat defective -----	Replace the rheostat (par. 52).
Resistor defective -----	Replace the resistor (par. 52).
Electrical connections loose or defective.	Tighten loose or replace faulty connections.
Welding current relay capacitor defective.	Replace the capacitor (par. 54).
Trigger switch relay defective.	Replace the relay (par. 57).
Power switch defective ----	Replace the switch (par. 51).

Section V. FIELD EXPEDIENT REPAIRS

45. General

Operator and organizational maintenance troubles may occur while the welding set is

operating in the field where supplies and repair parts are not available and normal corrective action cannot be performed. When this

rendition exists, the following expedient repairs may be used in emergencies, upon the decision of the unit commander. Equipment so repaired must be removed from operation as soon as possible and properly repaired before being placed in operation again.

46. Wire Fails to Feed When Inching Switch Is Pressed

<i>Trouble</i>	<i>Expedient remedy</i>
Inching switch defective.	Feed the welding wire through the gun by hand and operate the set without the inching switch (par. 88).

47. Welder Will Not Operate When Power Switch Is placed in the ON Position

<i>Trouble</i>	<i>Expedient remedy</i>
Power switch defective	Remove the switch (par. 51). Tape the leads together and operate the welding set without the switch.

Note. Disconnect the control cable from the welder before performing the field expedient repair above.

Warning: Performing any field expedient repair creates a condition possibly dangerous to personnel or equipment. A welding set so repaired should be taken out of service as soon as possible for replacement of defective parts.

Section VI. ARGON GAS SYSTEM

48. General

The components of the welding set argon gas system are a gas regulator which can be adjusted to deliver the cubic feet of gas per hour as needed, and which also registers the pressure of the gas cylinder; a 10-foot hose connecting the regulator and the control assembly ; an electrically operated gas solenoid valve located inside the control assembly; two short lengths of metal pipe extending from the solenoid valve to the front and rear of the control assembly; a 50-foot hose connecting the welding gun to the control assembly, and the necessary fittings required to connect the system.

49. Hose Assembly, Solenoid Valve, and Gas Pipe

a. Removal.

- (1) Refer to paragraph 10 and remove the gas regulator.
- (2) Refer to figure 11 and remove the hose assembly, solenoid valve, and gas pipe.

b. Cleaning and Inspection.

- (1) Clean the hose and gas pipe with a cloth dampened with an approved solvent. Clean the solenoid valve with a dry, lint-free cloth or dry Compressed air.

- (2) Inspect the hose for cracks, kinks, and breaks and the pipe for cracks and worn or stripped threads. Replace as required. Inspect the solenoid valve for broken or frayed electrical leads, corrosion, and signs of deterioration. Replace if necessary.

c. Testing. Test the solenoid valve as follows:

- (1) Use a multimeter set on RX100 ohm scale. Touch the probes of the multimeter to the solenoid leads.
- (2) The ohm scale should read 1,950 ohms ± 5 percent.
- (3) Replace the solenoid valve if it does not meet this test requirement.
- (4) Apply air pressure to the inlet port of the valve and check for leaks through the valve by using a soap and water solution on the outlet port. The presence of bubbles indicates an internal leak and the valve must be replaced.

d. Installation.

- (1) Refer to figure 11 and install the hose assembly, solenoid valve, and gas pipe.
- (2) Refer to paragraph 10 and install the gas regulator.

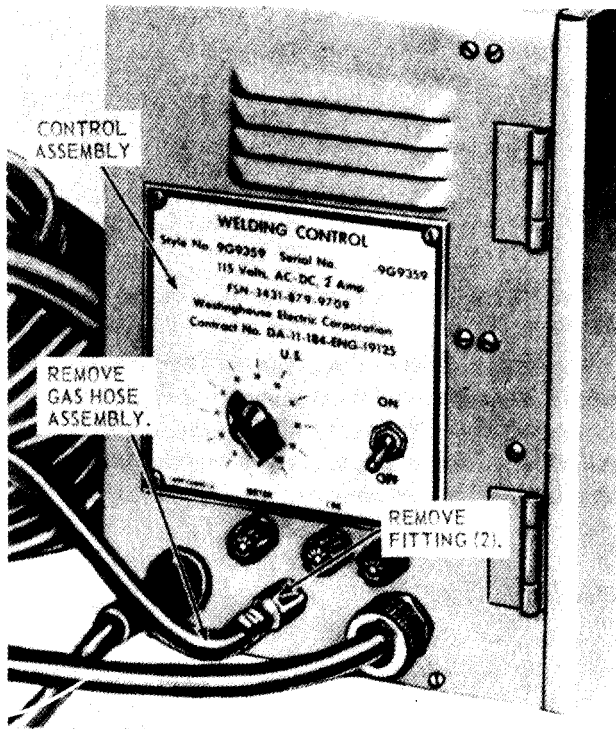

A. GAS HOSE CONNECTION AT CONTROL ASSEMBLY.

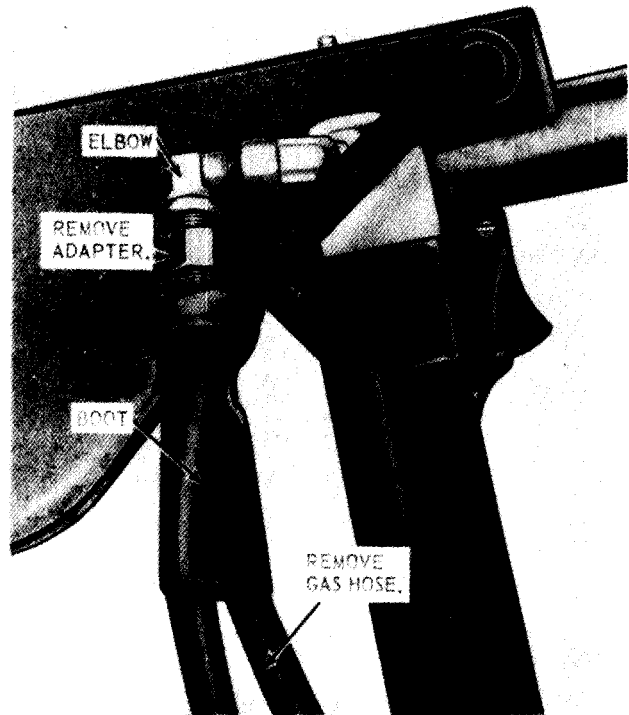

B. GAS HOSE CONNECTION AT GUN.

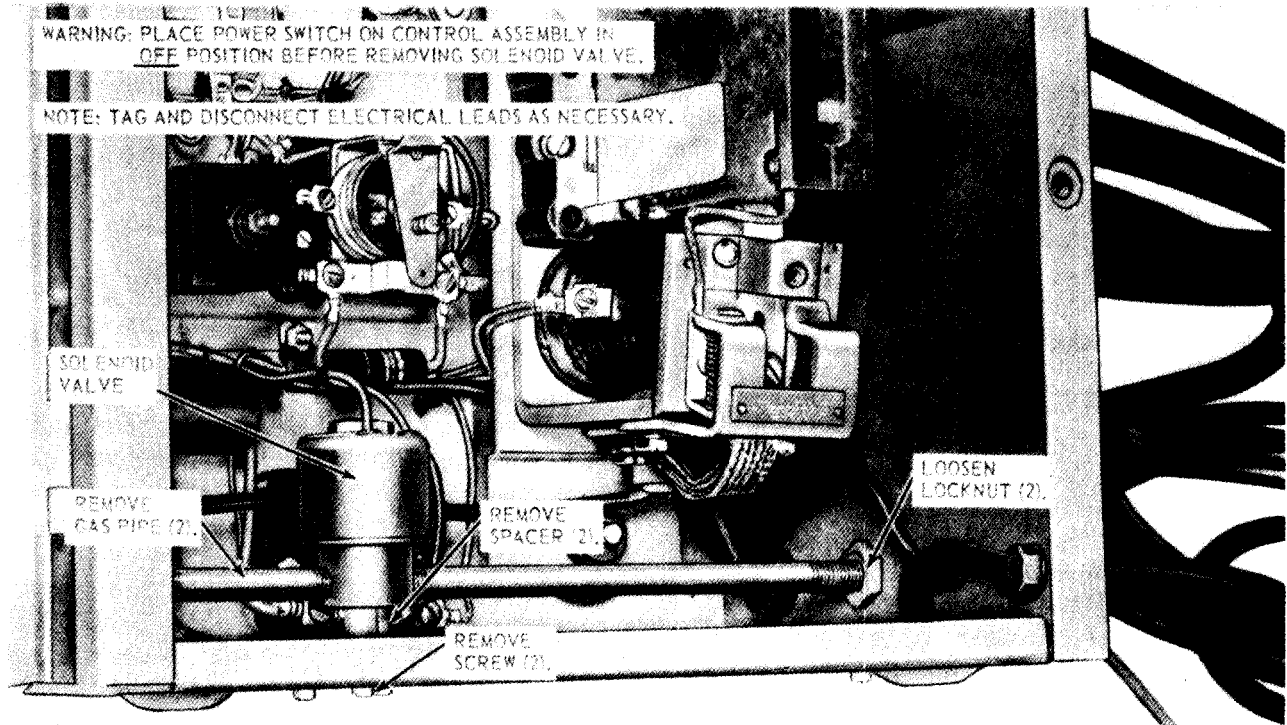

C. SOLENOID VALVE AND GAS PIPE.

EMC 3431-200-15 11

Figure 11. Hose assembly, solenoid valve, and gas pipe, removal and installation.

Section VII. ELECTRICAL SYSTEM

50. General

This section contains maintenance instructions for the electrical components of the welding gun and control assemblies. Figures 3 and 19 respectively, are the practical and schematic wiring diagrams of the welding set electrical system.

Warning: Disconnect source of power from welding set before performing any electrical maintenance.

51. Cable Assemblies, Grip, Strain Reliefs, Power Switch, and Terminal Strip

a. Removal. Refer to figure 12 and remove the cable assemblies, grip, strain reliefs, power switch, and terminal strip.

b. Cleaning and Inspection.

- (1) Clean all parts with a dry, lint-free cloth or with dry compressed air,
- (2) Inspect the cable assemblies, grip, and strain reliefs for cracks, breaks, and deterioration. Inspect the power switch and terminal strip for security of mounting and for worn or stripped threads on terminal screws. Replace damaged and defective parts,

c. Installation. Refer to figure 12 and install the cable assemblies, grip, strain reliefs, power switch, and terminal strip.

d. Field Expedient Repair. If the power switch is defective remove the switch, tape the leads together, and operate the welding set without the switch until replacement can be made.

Warning: While the power switch leads are taped together, the welding set cannot be turned off, except by disconnecting the outside power source. Do not attempt maintenance on the electrical system while the set is operating under field expedient repair conditions without disconnecting the power source.

52. Welding Wire Feed Control Rheostat, Rheostat Resistor, and Fuse Holders

a. Removal. Refer to figure 13 and remove the welding wire feed control rheostat, rheostat resistor, and fuse holders.

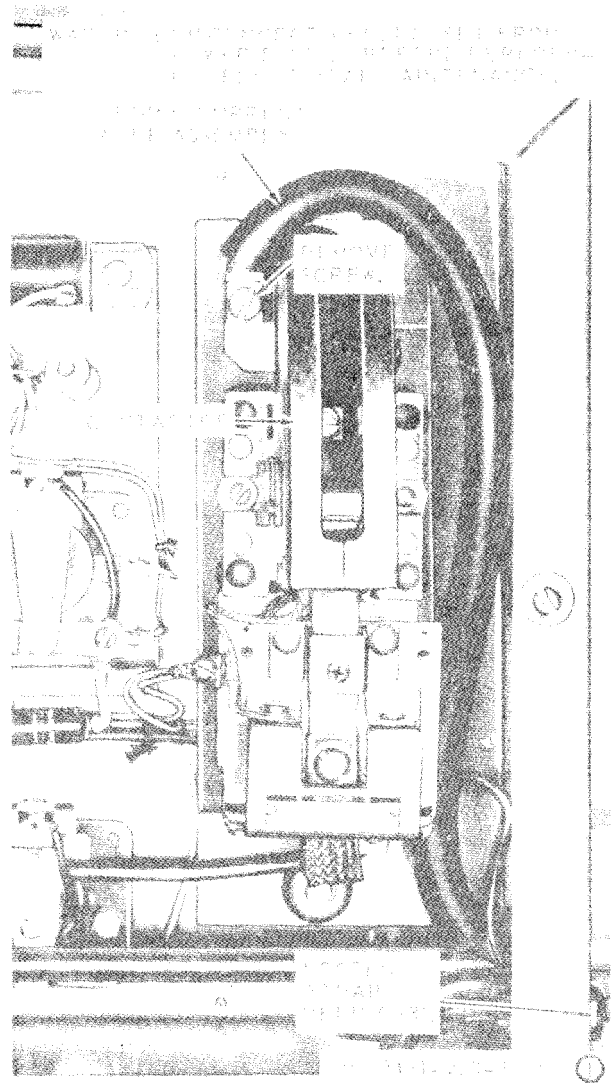

Figure 12. Cable assemblies, grip, strain reliefs, power switch, and terminal strip, removal and installation

b. Cleaning and Inspection.

- (1) Clean the welding wire feed control rheostat, rheostat resistor, and fuse holders with a dry, lint-free cloth.
- (2) Inspect for cracks, breaks, security of mounting, and improper operation. Replace damaged and defective parts.

c. Welding Wire Feed Control Rheostat Testing. Test the rheostat by performing the following steps:

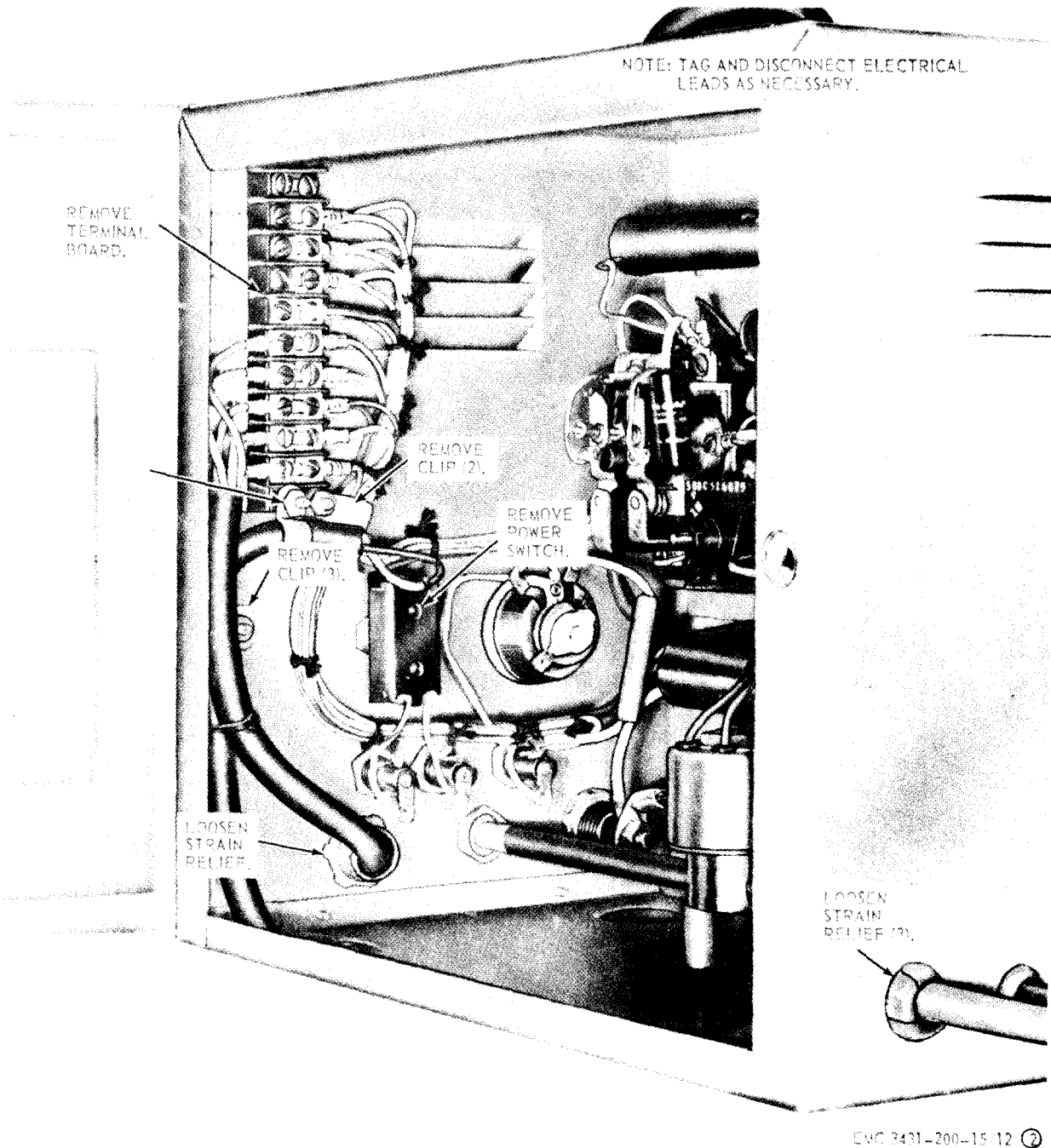

Figure 18—Continued.

Use a multimeter set on RX1 ohm scale and touch the probes of the meter to both outside terminals of the rheostat. The reading on the scale should be approximately 50 ohms \pm 1 percent.

(2) Replace the rheostat if it does not meet the above test specification.

d. *Rheostat Resistor Testing.* Test the rheostat resistor by performing the following steps:

(1) Use a multimeter set on RX1 ohm scale and touch the probes of the

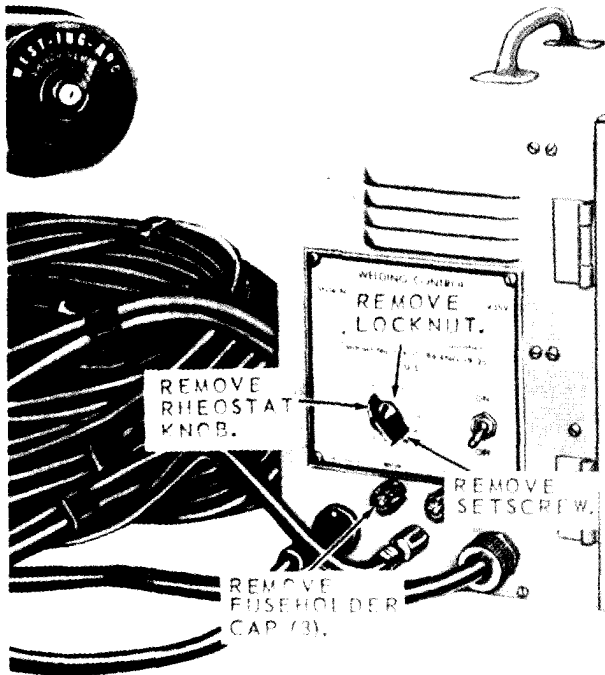

A. RHEOSTAT KNOB AND FUSEHOLDER CAPS.

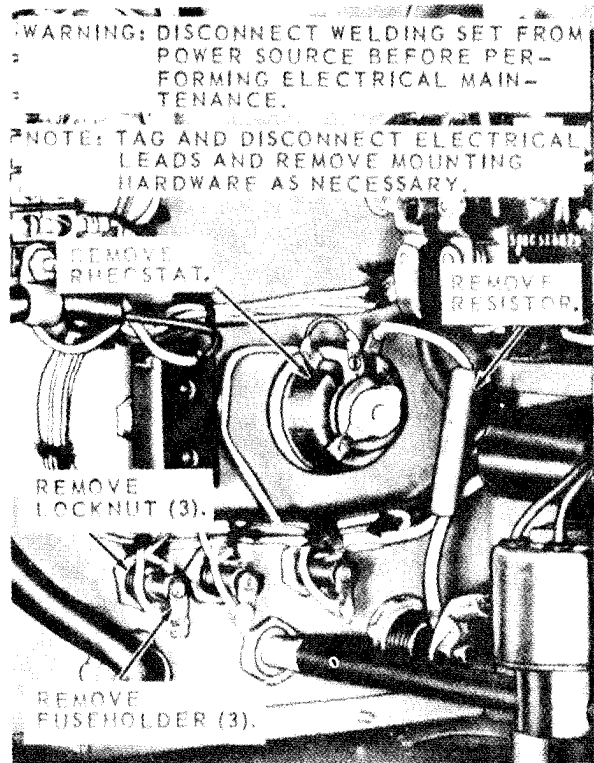

B. RHEOSTAT, RESISTOR, AND FUSEHOLDERS.

EMC 3431-200-15/13

Figure 13. Welding wire feed control rheostat, rheostat resistor, and fuse holders, removal and installation.

multimeter to the two terminals of the resistor.

- (2) Resistance should measure 5.0 ohms \pm 10 percent.
- (3) Replace a resistor which does not meet these specifications.

e. *Installation.* Refer to figure 13 and install the welding wire feed control rheostat, rheostat resistor, and fuse holders.

53. Contractor

a. *Removal.*

- (1) Refer to paragraph 51 and remove the cable assembly.
- (2) Refer to figure 14 and remove the contactor.

b. *Cleaning and Inspection.*

- (1) Clean the contactor with a dry, lint free cloth or with compressed air.

- (2) Inspect for worn or stripped threads on mounting and terminal hardware, defective wiring, and general condition. Repair or replace the contactor as required.

c. *Testing.*

- (1) Use a multimeter set to a suitable ohm scale and touch the probes of the multimeter to the two coil terminals.
- (2) The average resistance should read 240 ohms, with a maximum allowable resistance of 252 ohms and a minimum allowable resistance of 226 ohms.
- (3) Replace a defective contactor or report a repairable contactor to field maintenance.

d. *Installation.*

- (1) Refer to figure 14 and install the contactor.

ARNING:
DISCONNECT WELDING SET FROM POWER
BEFORE PERFORMING ELECTRICAL
MAINTENANCE.

NOTE: TAG AND DISCONNECT ELECTRICAL LEADS.

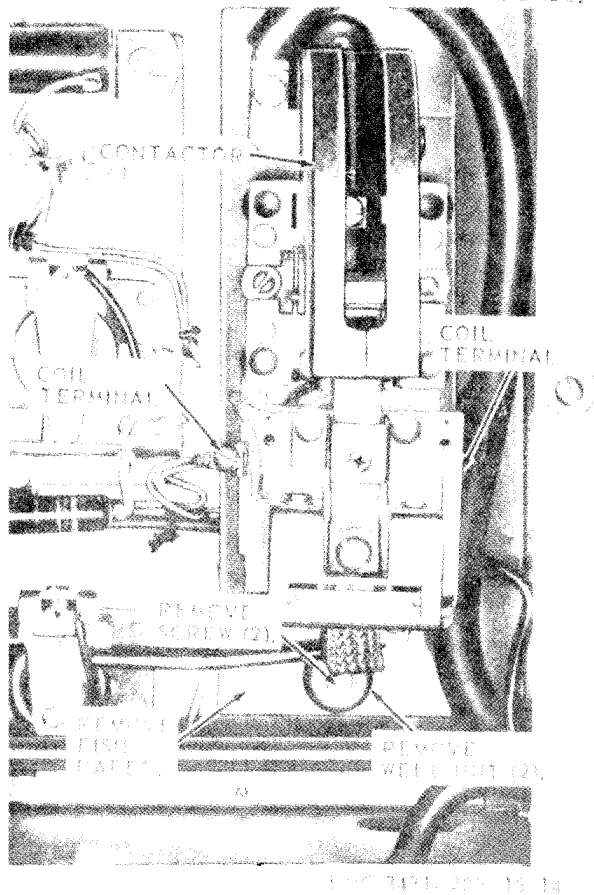

Figure 14. Contactor, removal and installation.

- (2) Refer to paragraph 51 and install the cable assembly.

54. Current Relay, Current Relay Capacitor, and Receptacle

a. Removal. Refer to figure 15 and remove the current relay, current relay capacitor, and receptacle.

b. Cleaning and Inspection.

- (1) Clean the current relay, capacitor, and receptacle with a dry, lint-free cloth.
- (2) Inspect for worn or stripped threads on mounting and terminal hardware

and for broken insulation on electrical leads. Replace defective parts.

c. Current Relay Capacitor Testing. To test the current relay capacitor, perform the following steps:

- (1) Use a standard capacitor tester and test for capacitance.
- (2) Touch the probes of the tester to the terminals of the capacitor leads.
- (3) The rated capacitance is 300 μf at 150 working volts, dc.
- (4) Replace the capacitor if it does not meet the above rating

d. Installation. Refer to figure 15 and install the current relay, current relay capacitor, and receptacle.

55. Control Panel Assembly

a. Removal. Refer to figure 16 and remove the control panel assembly from the control assembly,

b. Disassembly.

- (1) Refer to figure 16 and remove the rectifier.
- (2) Refer to figure 16 and remove the inching feed, the inching speed, and the contactor resistors.
- (3) Refer to figure 16 and remove the inching switch relay capacitor, the trigger switch relay capacitor, and the rectifier filter capacitor.
- (4) Refer to figure 16 and remove the trigger switch relay.
- (5) Refer to figure 16 and remove the inching switch relay.

c. Cleaning and Inspection.

- (1) Clean the control panel with an approved solvent and dry thoroughly.
- (2) Inspect for breaks, cracks, enlarged mounting holes, and distortion. Replace if necessary.

d. Reassembly.

- (1) Refer to figure 16 and install the inching switch relay.
- (2) Refer to figure 16 and install the trigger switch relay.
- (3) Refer to figure 16 and install the

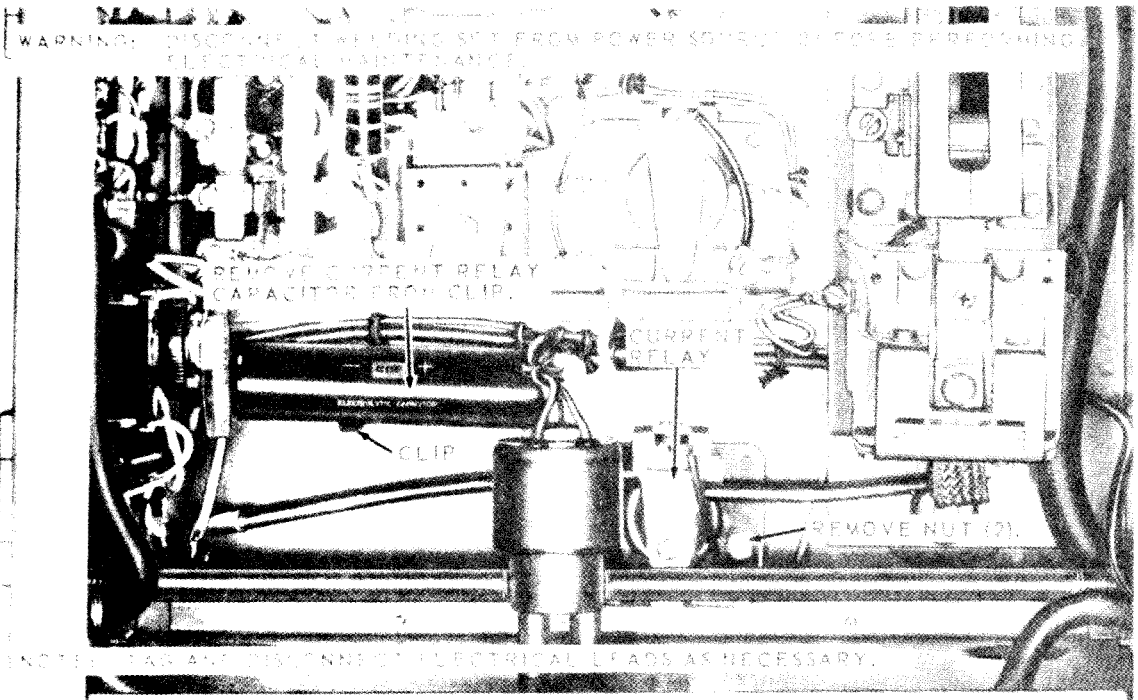

A. CURRENT RELAY AND CURRENT RELAY CAPACITOR.

WARNING: DISCONNECT WELDING SYSTEM FROM POWER SOURCE BEFORE PERFORMING ELECTRICAL MAINTENANCE.

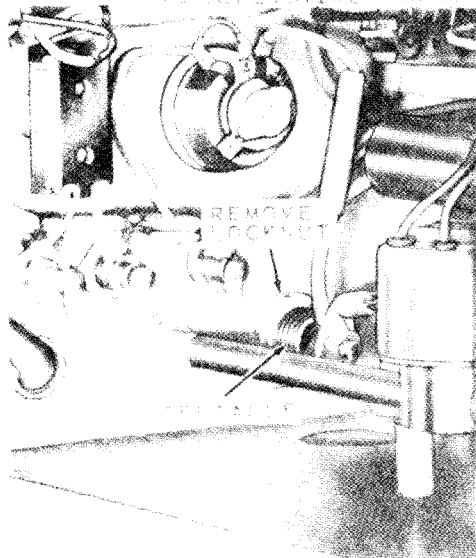

B. RECEPTACLE REMOVAL.

Figure 15. Current relay, current relay capacitor, and receptacle, removal and installation.

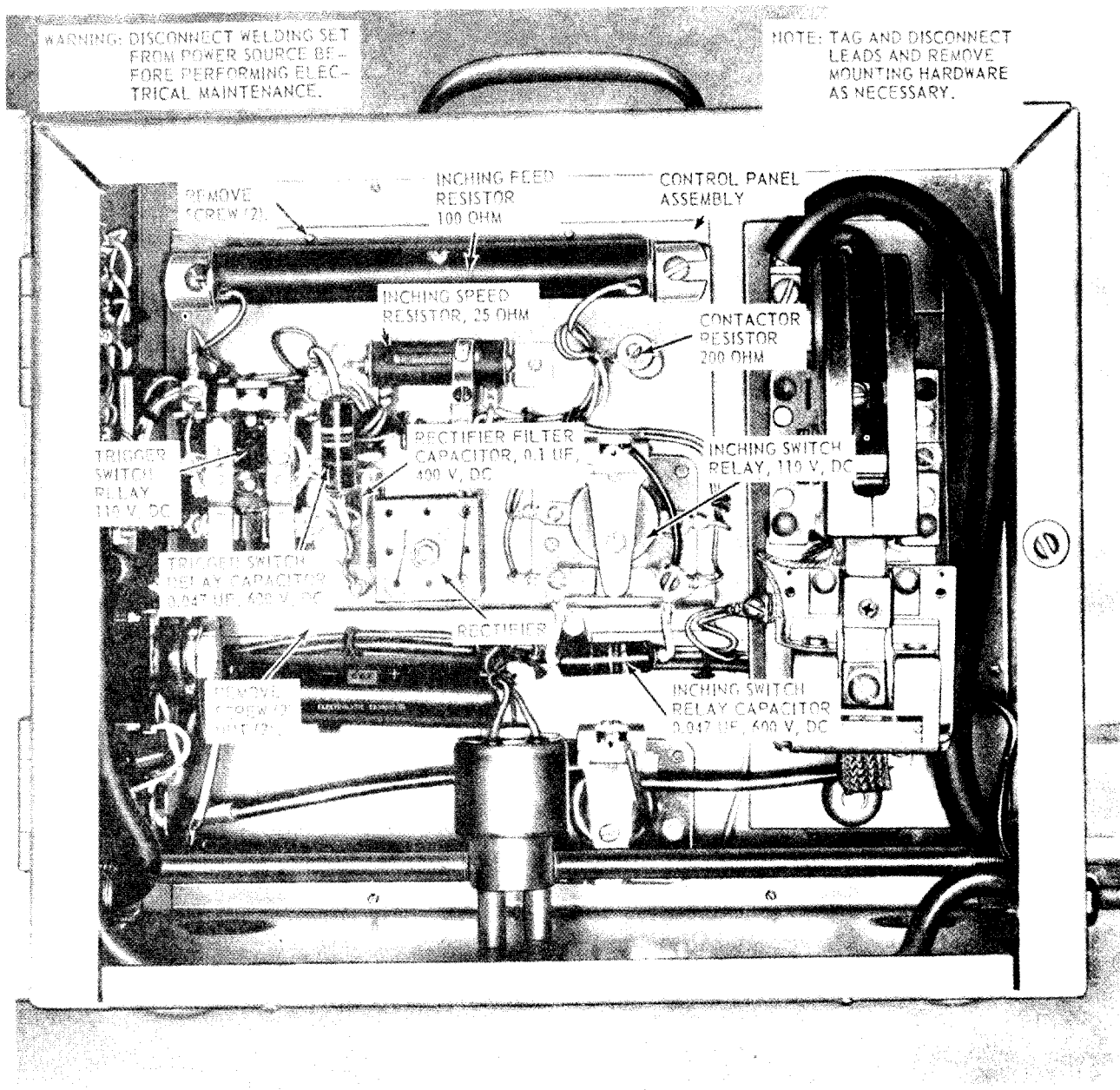

TM 5-3431-200-15 14

Figure 16. Control panel assembly, removal and installation.

- (4) Refer to figure 16 and install the inching feed, the inching speed, and the contactor resistors.

- (5) Refer to figure 16 and install the rectifier.
- e. *Installation.* Refer to figure 16 and install the control panel assembly in the control assembly.

56. Rectifier

a. Removal. Refer to figure 16 and remove the rectifier.

Warning: When a malfunction of the selenium rectifier occurs, thoroughly ventilate the area to prevent inhalation of poisonous fumes. Do not handle the damaged rectifier. Selenium oxide may be absorbed through the skin, especially when the rectifier is hot. Failure to observe this warning can result in severe illness or death.

b. Cleaning and Inspection.

- (1) Clean the rectifier with a dry, lint-free cloth or with dry compressed air.
- (2) Inspect for breaks, cracks, loose or missing terminal connections, and frayed or broken insulation on electrical leads. Tighten or replace loose or missing terminals. Replace the rectifier if damaged.

c. Testing. Perform the following rectifier test

- (1) Place the probes of an ohmmeter on one sc terminal and one dc terminal of the rectifier. Position the ohmmeter for X100 ohms and note the reading on the ohmmeter scale.
- (2) Reverse the probes on the two terminals and note the reading.
- (3) Compare the two readings. Replace the rectifier if the high reading is less than 10 times greater than the low reading.
- (4) Repeat (1), (2), and (3) above to test the rectifier through the remaining ac and dc terminals.

d. Installation. Refer to figure 16 and install the rectifier on the control panel.

57. Trigger Switch Relay

a. Removal. Refer to figure 16 and remove the trigger switch relay.

b. Cleaning and Inspection.

- (1) Clean the relay with a dry, lint-free cloth or dry compressed air.
- (2) Inspect for corroded contacts, missing terminal hardware, worn or stripped threads, and deterioration. Clean con-

tacts with a fine file; replace missing hardware and a damaged relay.

c. Testing.

- (1) Use a multimeter set on suitable ohm scale and touch the probes of the multimeter to the trigger switch relay coil terminals.
- (2) The multimeter should register 6,050 ohms \pm 5 percent resistance.
- (3) Replace a relay which does not meet the above test specifications.

d. Installation. Refer to figure 16 and install the trigger switch relay.

58. Inching Switch Relay

a. Removal Refer to figure 16 and remove the inching switch relay.

b. Cleaning and Inspection.

- (1) Clean the relay with a dry, lint-free cloth or with dry compressed air.
- (2) Inspect for corroded contacts, missing terminal hardware, worn or stripped threads, and general deterioration. Clean contacts with a fine file; replace missing hardware and a damaged relay.

c. Testing. Follow the same procedure to test the inching switch relay as that given for testing the trigger switch relay in paragraph 57. The values are identical.

d. Installation. Refer to figure 16 and install the inching switch relay.

59. Inching Feed, Inching Speed, and Contractor Resistors

a. Removal. Refer to figure 16 and remove the inching feed, inching speed, and contractor resistors.

b. Cleaning and Inspection.

- (1) Clean with a dry, lint-free cloth or dry compressed air.
- (2) Inspect for corrosion, deterioration, and worn or stripped threads on mounting and terminal hardware. Replace damaged or defective parts.

c. Testing. Use a multimeter set on appropriate ohm scale and touch the probes to the resistor terminals. The inching feed resistor

should indicate 100 ohms \pm 5 percent resistance; the inching speed resistor should indicate 25 ohms \pm 5 percent; the contactor resistor should show resistance of 200 ohms \pm 5 percent. Replace a resistor that does not meet these requirements.

d. Installation. Refer to figure 16 and install the inching feed, inching speed, and contactor resistors,

60. Trigger Switch Relay Capacitor, Inching Switch Relay Capacitor, and Rectifier Filter Capacitor

a. Removal. Refer to figure 16 and remove the trigger switch relay capacitor, inching switch relay capacitor, and the rectifier filter capacitor.

b. Cleaning and Inspection.

- (1) Clean the capacitors with a dry, lint-free cloth.

- (2) Inspect for corrosion, deterioration, and for worn or stripped threads on mounting hardware. Replace damaged or defective material.

c. Testing.

- (1) Use a standard capacitor tester. Touch the tester probes to the capacitor leads.
- (2) The rated capacitance of the trigger switch relay capacitor and the inching switch relay capacitor is 0.047 μ f at 600 working volts direct current. The rectifier filter capacitor is rated 0.1 μ f at 400 working volts, direct current.
- (3) Replace a capacitor that does not conform to the stated ratings.

d. Installation. Refer to figure 16 and install the trigger switch relay capacitor, inching switch relay capacitor, and the rectifier filter capacitor.

Section VIII. WELDING GUN

61. Welding Gun Cover, Shield, Fitting Assembly, Swing Arm, and Current Cable

a. Removal.

- (1) Refer to paragraph 49 and remove the hose assembly.
- (2) Refer to figure 17 and remove the cover, shield, fitting assembly, swing arm, and current cable.

b. Cleaning, Inspection, and Repair.

- (1) Clean the gun cover, shield, fitting assembly, swing arm, and current cable with a dry, lint-free cloth.
- (2) Inspect for cracks, breaks, broken insulation, and worn or stripped threads on fittings and hardware. Repair or replace damaged or defective parts,

c. Installation.

- (1) Refer to figure 17 and install the cover, shield, fitting assembly, swing arm, and current cable.

- (2) Refer to paragraph 49 and install the hose assembly.

62. Nozzle, Adapter, Guide Tube, Gun Tube, Gun Barrel, and Insulation

a. Removal. Refer to figure 18 and remove the nozzle, adapter, guide tube, gun tube, gun barrel, and insulation.

b. Cleaning, Inspection, and Repair.

- (1) Clean all parts with a dry, lint-free cloth. Clean the gun barrel gas ports after each 100 hours of use to remove spatter or other obstructions.
- (2) Inspect for cracks, breaks, worn threads, leaks, and signs of deterioration. Repair or replace damaged or defective parts.

c. Installation. Refer to figure 18 and install the nozzle, adapter, guide tube, gun tube, gun barrel, and insulation.

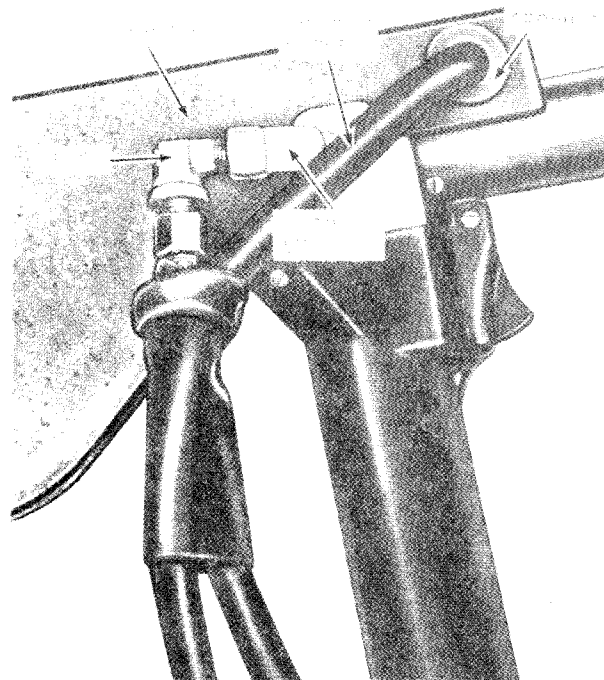
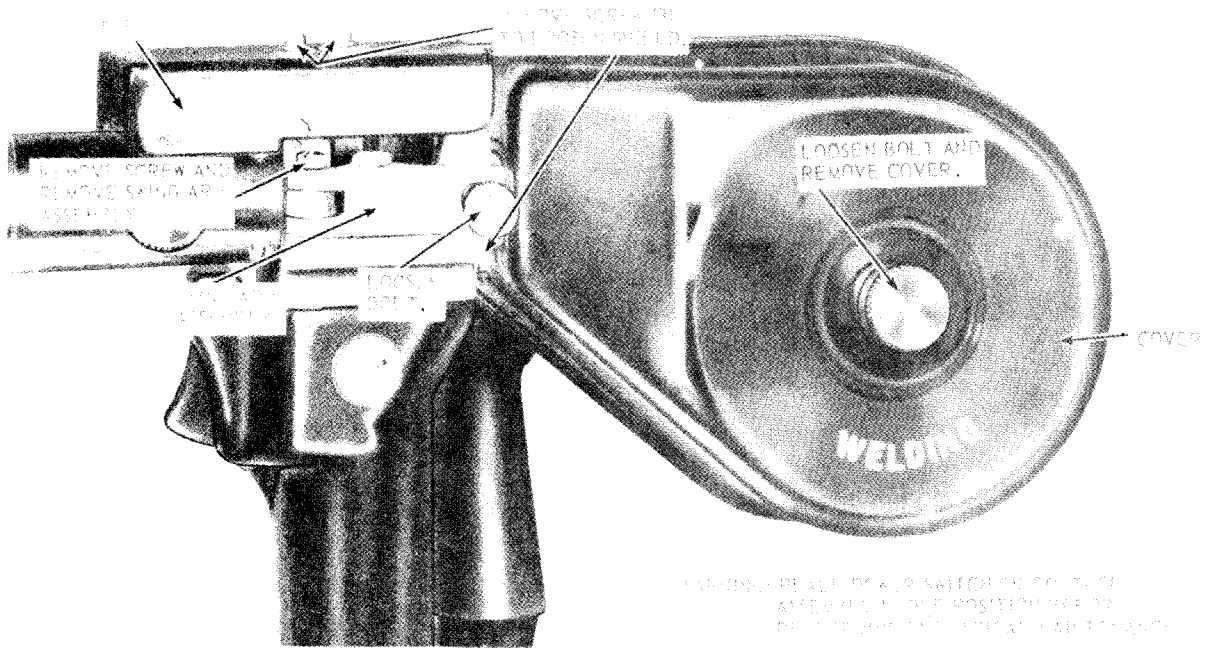
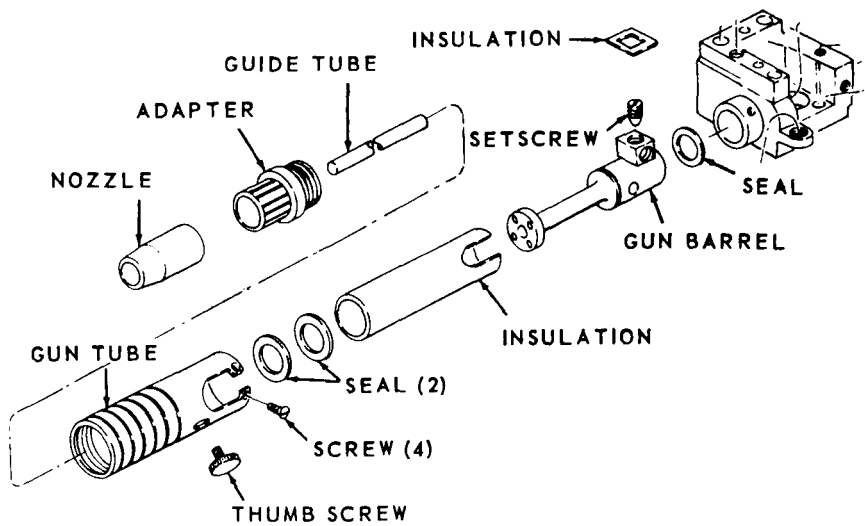

Figure 17. Cover, shield, fitting assembly, swing arm, and current cable, removal and installation.



EMC 3431-200-15/18

Figure 18. Nozzle, adapter, guide tube, gun tube, gun barrel, and insulation, removal and installation.

CHAPTER 4

DEMOLITION OF WELDING SET TO PREVENT ENEMY USE

63. General

When capture or abandonment of the welding set to an enemy is imminent, the responsible unit commander must make the decision either to destroy the welding set or to render it inoperative. Based on this decision, orders are issued which cover the desired extent of destruction. Whatever method of demolition is employed, it is essential to destroy the same vital parts of all welding sets and all corresponding repair parts.

64. Demolition To Render the Welding Set Inoperative

Use sledge hammers, crowbars, picks, axes, or any other available heavy tool to destroy the following:

- a. Welding gun assembly.
- b. Argon gas regulator.
- c. Contactor.
- d. Control panel assembly and controls.
- e. Solenoid valve.

65. Other Demolition Methods

a. *Scattering and Concealment.* Remove all easily accessible parts such as the gun and reg-

ulator and scatter them in dense foliage, bury them in sand or dirt, or throw them in a lake, stream, or other body of water.

b. *Burning.* Pack rags, canvas, or clothing around and inside the welding set. Saturate with oil, fuel oil, or gasoline and ignite.

c. *Submersion.* Fully submerge the welding set in a body of water to provide water damage and concealment. Salt water will damage metal parts more than fresh water.

66. Training

All operators should receive thorough training in the destruction of the welding set. Refer to FM 5-25. Simulated destruction, using all of the methods listed above, should be included in the operator training program. It must be emphasized in training that demolition operations are usually necessitated by critical situations, when time available for carrying out destruction is limited. For this reason, it is necessary that operators be thoroughly familiar with all methods of destruction of equipment, and be able to carry out demolition instructions without reference to this or any other manual.

CHAPTER 5

SHIPMENT AND LIMITED STORAGE

Section I. SHIPMENT WITHIN ZONE OF INTERIOR

67. Preparation of Equipment for Shipment

a. *General.* Detailed instructions for the preparation for domestic shipment are outlined within this paragraph. Preservation will be accomplished in sequence that will not require the operation of previously preserved components.

b. *Inspection.* Equipment will be inspected for any unusual condition such as damage, rusting, accumulation of water, or pilferage. DA Form 464, Work Sheet for Preventive Maintenance and Technical Inspection of Engineer Equipment, will be executed on the equipment.

c. *Cleaning and Drying.* Thorough cleaning and drying by an approved technique is the first essential procedure in any effective preser-

vation process. Approved methods of cleaning, drying, types of preservatives, and methods of application are described in TM 38-230.

d. *Marking.* Shall conform to MIL-STD-129.

e. *Packing.* Place the items in the original crate or if it is not available fabricate a new crate. Refer to TM 38-230 for guidance in crate fabrication.

68. Loading the Equipment for Shipment

a. The crated welding set may be loaded manually by two men or by a forklift truck.

b. Block or tie the crated welding set, top side up, to the bed of the carrier to prevent shifting during transportation.

c. Cover the crated welding set with a waterproof covering.

Section II. LIMITED STORAGE

69. Preparation of Equipment for Storage

a. *General.* Detailed instructions for preserving and maintaining equipment in limited storage are outlined in this paragraph. Limited storage is defined as storage not to exceed 6 months. Refer to AR 743-505.

b. *Inspection.* Equipment will be inspected for any unusual condition such as damage, rusting, accumulation of water, or pilferage. DA Form 464, Work Sheet for Preventive Maintenance and Technical Inspection of Engineer Equipment will be executed on the equipment.

c. *Cleaning and Drying.* Thorough cleaning and drying by an approved technique is the first essential procedure in any effective preservation process. Approved methods of cleaning,

drying, types of preservatives, and methods of application are described in TM 38-230.

d. *Packing.* Place the items in the original crate or if it is not available, fabricate a new crate. Refer to TM 38-230 for guidance in crate fabrication.

e. *Weatherproofing.* Welding set will be provided dry covered storage.

70. Inspection and Maintenance of Equipment in Storage

a. *Inspection.* When the welding set has been placed in storage, all scheduled preventive maintenance services, including inspection, shall be suspended and preventive maintenance inspection shall be performed as specified herein. Refer to AR 743-505.

b. Worksheet and Preventive Maintenance. DA Form 464 shall be prepared for each welding set when initially placed in limited storage, and every 90 days thereafter. Perform re-

quired maintenance promptly to make sure the welding set is mechanically sound and ready for immediate use.

CHAPTER 6

FIELD AND DEPOT MAINTENANCE INSTRUCTIONS

Section I. GENERAL

71. Scope

a. The following instructions are for field and depot maintenance personnel. They contain information on equipment maintenance that is beyond the scope of the tools, equipment, personnel, and supplies normally available to organizational maintenance.

b. Appendix I includes the publications applicable to field and depot maintenance. Appendix II contains the Maintenance Allocation Chart. The Field and Depot Maintenance Re-

pair Parts and Special Tool Lists are listed in TM 5-3431-200-25P.

72. Record and Report Forms

For record and report forms applicable to field and depot maintenance, refer to TM 5-505.

Note. Applicable forms, excluding Standard Form 46 which is carried by the operator, shall be kept in a canvas bag mounted on the welding set.

Section II. DESCRIPTION AND DATA

73. Description

For a complete description of the welding set, Westinghouse Model SA-135, see paragraph 3.

74. Tabulated Data

a. Contactor.

Manufacturer-----Westinghouse Electric Corp.
 Type----- MM410
 Style -----552D 181 G02
 Resistance, ohms:
 High-----252
 Low-----266
 Average-----240

b. Welding Gun Motor.

Manufacturer-----Globe Industries
 Model-----29A571
 Volts-----24dc
 Armature resistance 12 ohms (minimum) including brushes.
 Full load torque-----12 ounce inches (minimum) (continuous)
 No load speed-----9.800 rpm maximum
 Gear ratio-----18.78:1

c. Wiring Diagram. Figure 19 is a schematic wiring diagram of the welding set.

d. Time Standards. Table I lists the number of man-hours required under normal conditions to perform the indicated maintenance and repair of the welding set. Components are listed under the appropriate functional index. The times listed are not intended to be rigid standards. Under adverse conditions, the operations will take longer; but under ideal conditions, with highly skilled mechanics, most of the operations can be accomplished in considerably less time.

Table I. Time Standards

	Remove and replace	Hours
44	WELDING, METALIZING, METAL HEATING AND PLATING EQUIPMENT	
4403	GAS WELDING, FLAME CUTTING Regulator, gas _____	0.2

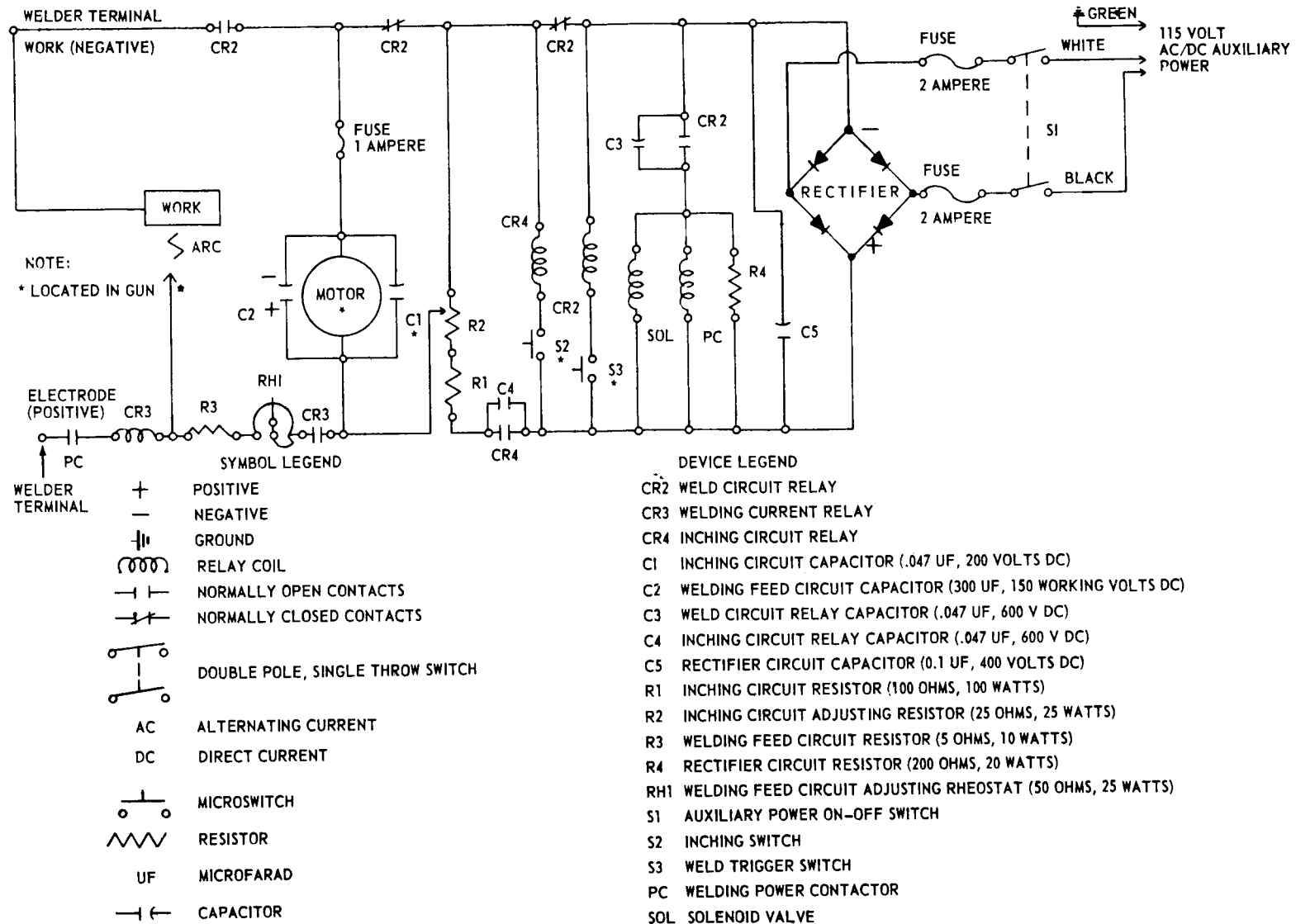

Figure 19. Schematic wiring diagram.

Table I. Time Standards-Continued

	Remove and Replace	Hours
4406.3	CONTROL PANELS, HOUSINGS, CUBICLES Control assembly -----	4.0
4406.4	CONNECTING DEVICES Receptacle ----- Cable assembly ----- Hose assembly ----- Terminal strip -----	0.3 0.5 0.2 1.0
4406.5	PROTECTING DEVICES, ELECTRICAL Fuse -----	0.1

Table I. Time Standards-Continued

	Remove and replace	Hours
4406.6	SWITCHING, TIMING AND SPEED CONTROL Switches ----- Contactor ----- Relay ----- Capacitor -----	0.3 0.3 0.5 0.4
4406.7	RESISTORS Rheostat ----- Resistors -----	0.5 0.3
4406.9	RECTIFIERS Rectifier -----	0.6
4406.11	HEAD, TORCH AND GUN UNITIZED COMPONENTS Gun assembly -----	1.0

Section III. SPECIAL TOOLS AND EQUIPMENT

75. Special Tools and Equipment

No special tools or equipment are required by field and depot maintenance personnel for the maintenance of the welding set

76. Field and Depot Maintenance Repair Parts

Field and depot maintenance repair parts

are listed and illustrated in TM 5-3431-200-25P.

77. Specially Designed Tools and Equipment

No specially designed tools or equipment are required by field and depot maintenance personnel for the maintenance of the welding set.

Section IV. TROUBLESHOOTING

78. General

This section provides information useful in diagnosing and correcting unsatisfactory operation or failure of the welding set or any of its components. Each trouble symptom stated is followed by a list of probable causes of trouble. The possible remedy recommended is described opposite the probable cause.

79. Contractor Fails to Close When Trigger Is Pressed

<i>Probable cause</i>	<i>Possible remedy</i>
Trigger switch defective,	Replace the trigger switch (par. 88).
Contacting coil defective.	Replace the contactor coil (par. 86).

80. Motor Fails to Run When Inching Switch Is Pressed

<i>Probable cause</i>	<i>Possible remedy</i>
Inching switch defective.	Replace the inching switch (par. 88).
Motor defective -----	Replace the motor (par. 88).

81. Wire Will Not Feed

<i>Probable cause</i>	<i>Possible remedy</i>
Wire feed motor defective.	Replace motor (par. 88).

82. Wire Feed Speed Too Slow

<i>Probable cause</i>	<i>Possible remedy</i>
Wire feed motor erratic.	Replace motor (par. 88).

83. Wire Feed Speed Too Fast

Probable cause

Possible remedy

Wire feed motor erratic.

Replace motor (par. 88).

84. Welding Set Starts But Fails to Continue Welding.

Probable cause

possible remedy

Wire feed motor failure.

Replace motor (par. 88).

Section V. CONTACTOR MAINTENANCE INSTRUCTIONS

85. General

The contactor is mounted inside the control assembly next to the control panel on the left side. It completes the welding circuit from the welder to the gun when the trigger switch is pressed. The contactor contains a blowout coil which ruptures the arc to prevent high current from damaging the contacts.

86. Contactor

Warning: Disconnect the source of power from the welder before performing any electrical maintenance on the set.

a. Removal Refer to paragraph 53 and remove the contactor from the control assembly.

b. Disassembly. Refer to figure 20 and disassemble the contactor.

c. Cleaning, Inspection, and Repair.

(1) Clean all parts with a dry, lint-free cloth.

(2) Inspect for breaks, chips, broken insulation, and worn threads. Repair or replace damaged or defective parts.

d. Reassembly. Refer to figure 20 and reassemble the contactor. Refer to paragraph 53 and test the contactor.

e. Installation. Refer to paragraph 53 and install the contactor on the control assembly.

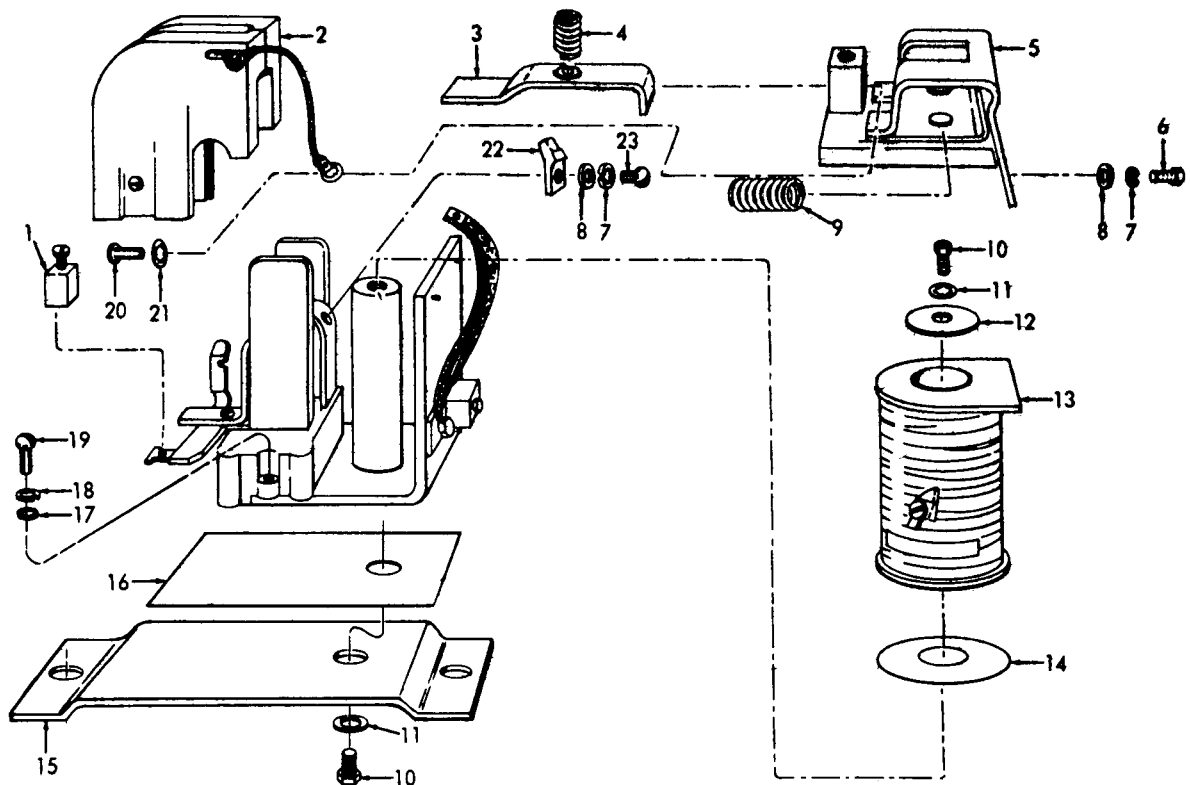

EMC 3431-200-15/20

- | | |
|--|--|
| 1 Terminal (2 rqr) | 13 Coil |
| 2 Arc box assembly | 14 Retaining washer |
| 3 Moving contact | 15 Contractor control panel |
| 4 Contact spring | 16 Fish paper |
| 5 Armature plate | 17 Washer, flat, 3/16 in. (2 rqr) |
| 6 Screw, machine, 1/4-20 x 1/2 in. (2 rqr) | 18 Washer, lock, 3/16 in. (2 rqr) |
| 7 Washer, lock, 1/4 in. (2 rqr) | 19 Screw, machine, No. 10-32 x 3/4 in. (2 rqr) |
| 8 Washer, flat, 1/4 in. (2 rqr) | 20 Screw, machine, No. 10-32 x 1/4 in. |
| 9 Kickout spring (2 rqr) | 21 Washer, lock, No. 10-32 (3 rqr) |
| 10 Screw, machine, 1/4-28 x 1/2 in. | 22 Stationary contact |
| 11 Washer, lock, 1/4 in. | 23 Screw, machine, 1/4-28 x 3/8 in. (2 rqr) |
| 12 Washer, flat, 1/4 in. | |

Figure 20. Contactor, disassembly and reassembly.

Section VI. GUN HANDLE ASSEMBLY MAINTENANCE INSTRUCTIONS

87. General

The gun handle incloses the motor, inching switch, trigger switch, capacitor, and control cable connections. With the exception of the welding current all connections from the gun to the control assembly are made through the

control cable. The drive roll is turned by the motor through the shaft to feed wire for the welding operation. Wire driving force is obtained by squeezing the wire between the knurled drive roll and an idler roll on the swing arm. Pressure on the welder roll is adjustable.

88. Gun Handle Assembly, Motor, Drive Roll, Control Cable, Inching Switch, Trigger Switch, Capacitor, and Bracket

Caution: Place the power switch on the control assembly on the OFF position before performing electrical maintenance on the gun assembly.

a. Removal.

- (1) Refer to paragraph 61 and remove the cover, shield, fitting assembly, swing arm and current cable.
- (2) Refer to paragraph 62 and remove the nozzle, adapter, guide tube, gun tube, gun barrel, and insulation.

b. Disassembly. Refer to figure 21 and dis-

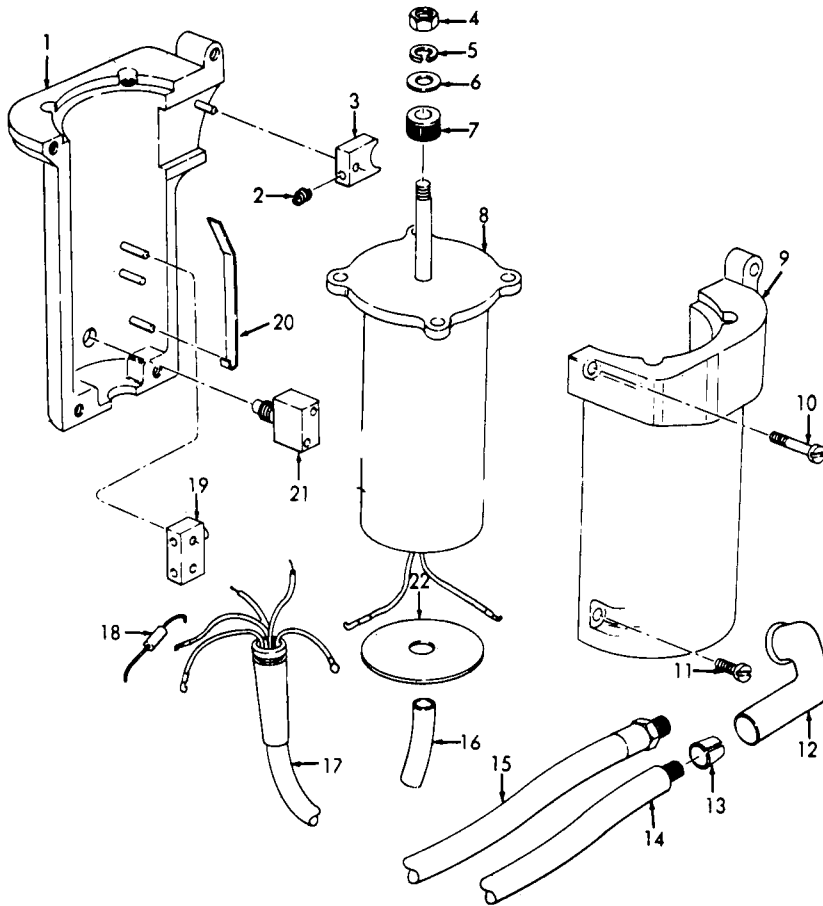

EMC 3431-200-15/21

- | | | |
|-------------------------|---|----------------------------|
| 1 Left handle housing | 9 Right handle housing | 17 Cable assembly |
| 2 Trigger spring | 10 Screw, machine, No. 6-32 x 5/8 in. | 18 Capacitor, 0.05 μ f |
| 3 Trigger | 11 Screw, machine, No. 6-32 x 3/8 in. (3 rqr) | 19 Trigger switch |
| 4 Nut, hex, 1/4-20 | 12 Boot | 20 Trigger spring |
| 5 Washer, lock, 1/4 in. | 13 Strap | 21 Inching switch |
| 6 Washer, flat, 1/4 in. | 14 Cable assembly | 22 Motor insulator |
| 7 Drive roll | 15 Hose assembly | |
| 8 Motor | 16 Slewing (2 rqr) | |

Figure 21. Gun handle assembly, motor, drive roll, control cable, inching switch, trigger switch, capacitor, and bracket, disassembly and reassembly.

c. Cleaning, Inspection and Repair.

- (1) Clean parts with a dry, lint-free cloth.
- (2) Inspect for cracks, breaks, frayed or broken insulation on electrical leads, worn threads on fittings and hardware, deterioration, and general condition. Repair or replace damaged or broken parts.

d. Capacitor Testing. Test the welding gun motor capacitor by performing (1) through (3) below.

- (1) Test as in paragraph 54.
- (2) The rate capacitance is 0.047 μ f at 100 working volts, dc.
- (3) Replace the capacitor if it does not indicate the above.

e. Motor Testing. Test the motor as follows:

- (1) Connect the motor to a suitable 24-v dc power supply,

- (2) Use a tachometer and test the armature speed. Maximum armature speed should be 9,800 rpm.
- (3) Replace a motor which does not test as specified.

f. Reassembly. Refer to figure 21 and reassemble the gun handle assembly and bracket.

g. Installation.

- (1) Refer to paragraph 62 and install the insulation, gun barrel, gun tube, guide tube, nozzle, and adapter.
- (2) Refer to paragraph 61 and install the current cable, swing arm, fitting assembly, shield, and cover.

h. Field Expedient Repair. If the inching switch is defective, feed the welding wire through the gun by hand. Make replacement of the switch as soon as possible.

APPENDIX I

REFERENCES

1. Dictionary of Terms and Abbreviations

- AR 320-5 Dictionary of United States Army Terms.
 AR 320-50 Authorized Abbreviations and Brevity Codes.

2. Painting and Preservation

- TB ENG 60 Preservation and Painting of Serviceable Corps of Engineers Equipment,

3. Preventive Maintenance

- AR 750-5 Maintenance Responsibilities and Shop Operation.
 TM 5-505 Maintenance of Engineer Equipment.

4. Publication Indexes

- DA PAM 108-1 Index of Army Motion Pictures, Film Strips, Slides, and Phono-Recordings.
 DA PAM 310-1 Index of Administrative Publications.
 DA PAM 310-2 Index of Blank Forms.
 DA PAM 310-3 Index of Training Publications.
 DA PAM 310-4 Index of Technical Manuals, Technical Bulletins, Supply Bulletins, Lubrication Orders, and Modification Work Orders.
 DA PAM 310-5 Index of Graphic Training Aids and Devices.
 DA PAM 310-25 Index of Supply Manuals, Corps of Engineers.

5. Shipment and Limited Storage

- AR 743-505 Limited Storage of Engineer Mechanical Equipment.
 TM 38-230 Preservation, Packaging, and Packing of Military Supplies and Equipment.

6. Supply Publications

- TM 5-3431-200-25P Organizational, Field, And Depot Maintenance Repair Parts and Special Tool Lists. Welding Set, Arc, Inert Gas Shielded: Plastic or Metal Lined Gun; for 3/64 in. Wire Ac Dc, 115 V (Westinghouse Model SA-135) FSN 3431-879-9709.

7. Training Aids

- FM 5-25 Explosive and Demolition.
 FM 21-5 Military Training.
 FM 21-6 Techniques of Military Instruction.
 FM 21-30 Military Symbols.

APPENDIX II

MAINTENANCE ALLOCATION

Section I. INTRODUCTION

1. General

This appendix contains explanations of all maintenance and repair functions authorized for the various echelons. Section II contains the Maintenance Allocation Chart.

2. Maintenance

Maintenance is any action taken to keep materiel in a serviceable condition or to restore it to serviceability when it is unserviceable. Maintenance of materiel includes the following:

a. Service. To clean, preserve, and replenish fuel and lubricants.

b. Adjust. To regulate periodically to prevent malfunction.

c. Inspect. To verify serviceability and detect incipient electrical or mechanical failure by scrutiny,

d. Test. To verify serviceability and detect incipient electrical or mechanical failure by use of special equipment such as gages, meters, and the like.

e. Replace. To substitute serviceable assemblies, subassemblies, and parts for unserviceable components.

f. Repair. To restore an item to serviceable condition through correction of a specific failure or unserviceable condition. This function includes, but is not limited to, inspecting, cleaning, preserving, adjusting, replacing, welding, riveting, and straightening.

g. Aline. To adjust two or more components of an electrical system so that their functions are properly synchronized.

h. Calibrate. To determine, check, or rectify the graduation of an instrument, weapon, or weapons system, or components of a weapons system.

i. Overhaul. To restore an item to completely serviceable condition as prescribed by service-

ability standards developed and published by heads of technical services. This is accomplished through employment of the technique of "Inspect and Repair Only as Necessary" (IROAN). Maximum utilization of diagnostic and test equipment is combined with minimum disassembly of the item during the overhaul process.

3. Explanation of Columns

a. Functional Group. The functional group is a numerical group set up on a functional basis. The applicable Functional Grouping Indexes (obtained from the Corps of Engineers Functional Grouping Indexes) are listed on the MAC in the appropriate numerical sequence. These indexes are normally set up in accordance with their function and proximity to each other.

b. Components and Related Operation. This column contains the Functional Grouping Index heading, subgroup headings, and a brief description of the part starting with the noun name. It also designates the operations to be performed such as service, adjust inspect, test replace, repair, and overhaul.

c. Echelons of Maintenance. This column contains the various echelons of maintenance by number designation. An X placed in the appropriate echelon column in line with an indicated maintenance function authorizes that echelon to perform the function. The "X" indicates the lowest echelon responsible for performing the function, but does not necessarily indicate repair parts stockage at that level. Higher echelons are authorized to perform the indicated functions of lower echelons.

d. Remarks. This column lists specific maintenance functions, special tools, cross-references, instructions, and the like pertinent to the operation being performed.

Section II. MAINTENANCE ALLOCATION

Functional Group	Components and related operation	Echelons of maintenance					Remarks
		1	2	3	4	5	
22	MISCELLANEOUS BODY, CHASSIS OR HULL, AND ACCESSORY ITEMS.						
2210	Data Plate and Instruction Holders. Plate, identification (C. O.E.):						
	Replace -----	--	--	X			
44	WELDING, METALIZING, METAL HEATING AND PLATING EQUIPMENT.						
4403	Gas Welding, Flame Cutting. Regulator:						
	Adjust -----	X					
	Replace -----	X					
4406.3	Control Panels, Housings, Cubicles. Control assembly:						
	Replace -----	--	X				
	Repair -----	--	X				
4406.4	Connecting Devices. Receptacle:						
	Replace -----	--	X				
	Cable assembly:						
	Replace -----	--	X				
	Hose assembly:						
	Replace -----	--	X				
	Terminal strip:						
	Replace -----	--	X				
	Cable assembly, gun:						
	Replace -----	--	--	X			
4406.5	Protective Devices, Electrical. Fuse:						
	Replace -----	X					
4406.6	Switching, Timing and Speed Control. Switches :						
	Replace -----	--	X				
	Contactors:						
	Test -----	--	X				
	Replace -----	--	X				
	Repair -----	--	--	X			
	Relay:						
	Test -----	--	X				
	Replace -----	--	X				
	Capacitor:						
	Test -----	--	X				
	Replace -----	--	X				
	Valve, solenoid:						
	Test -----	--	X				
	Replace -----	--	X				
	Switch, trigger and inching:						
	Replace -----	--	--	X			
	Capacitor, gun:						
	Test -----	--	--	X			
	Replace -----	--	--	X			

Functional Group	Components and related operation	Echelons of maintenance					Remarks
		1	2	3	4	5	
4406.7	Resistors.						
	Rheostat:						
	Adjust -----	X					
	Test -----	--	X				
	Replace -----	--	X				
	Resistors:						
Test -----	--	X					
Replace -----	--	X					
4406.9	Rectifiers.						
	Rectifier, semiconductor:						
	Test -----	--	X				
	Replace -----	--	X				
4406.11	Head, Torch and Gun Unitized Components.						
	Gun Assembly:						
	Service -----	X					
	Test -----	--	X				
	Replace -----	--	X				
	Repair -----	--	X				
	Overhaul -----	--	--	X			

APPENDIX III

BASIC ISSUE ITEMS

Section I. INTRODUCTION

1. General

Section II lists the accessories, tools, and publications required in 1st echelon maintenance and operation, initially issued with, or authorized for the welding set.

2. Explanation of Columns

a. Source Codes. The information provided in each column is as follows:

- (1) *Technical service.* This column lists the basic number (or symbol) of the technical service assigned supply responsibility for the part. Those spaces left blank denote Corps of Engineers supply responsibility. General Engineer supply parts are identified by the letters GE in parentheses, following the nomenclature in the description column. Other technical services basic numbers (or symbols) are:
 - 10-Quartermaster Corps
 - 12-Adjutant General's Corps
- (2) *Source.* The selection status and source of supply for each part are indicated by one of the following code symbols:
 - (a) P-applied to high-mortality repair parts which are stocked in or supplied from the technical service depot system, and authorized for use at indicated maintenance echelons.
 - (b) P1-applied to repair parts which are low-mortality parts, stocked in or supplied from technical service depots, and authorized for installation at indicated maintenance echelons.

- (3) *Maintenance.* The lowest maintenance echelon authorized to use, stock, install or manufacture the part is indicated by the following code symbol:

O-Organizational Maintenance
(1st and 2d Echelon)

b. Federal Stock Numbers. This column lists the n-digit Federal stock number used for requisitioning purposes.

c. Description.

- (1) The item name and a brief description of the part are shown.
- (2) A five-digit Federal supply code for manufacturers and/or other technical services is shown in parentheses followed by the manufacturer's part number. This number shall be used for requisitioning purposes when no Federal stock number is indicated.
Example: (08645) 86453
- (3) The letter GE, shown in parentheses immediately following the description, indicate General Engineer supply responsibility for the part.

d. Unit of Issue. Where no abbreviation is shown in this column, the unit of issue is "each".

e. Expendability. Those items classified as nonexpendable are indicated by letters NX. Items not indicated by NX are expendable.

f. Quantity Authorized. This column lists the quantities of repair parts, accessories, tools, or publications authorized for issue to the equipment operator or crew as required.

g. Quantity Issued with Equipment. This column lists the quantities of repair parts, accessories, tools, or publications that are initially issued with each item of equipment. Those indicated by an asterisk are to be requisitioned through normal supply channels as required.

h. Illustrations.

- (1) *Figure number.* Provides the identifying number of the illustration,
- (2) *Item number.* Provides the referenced number for the part shown in the illustration.

3. Federal Supply Code for Manufacturers

88725-----Westinghouse Electrical Corp.

4. Comments and Suggestions

Suggestions and recommendations for changes to the Basic Issue Items List shall be submitted on DA Form 2028 to the Commanding Officer, U.S. Army Engineer Maintenance Center, ATTN: EMCDM-S, P. O. Box 119, Columbus 16, Ohio. Direct communication is authorized.

Section II. BASIC ISSUE ITEMS

Source codes				Federal stock No.	Description	Unit of issue	Expendability	Quantity authorized	Quantity issued with equipment	Illustration	
Technical service	Source	Maintenance	Recoverability							Fig.	Item
					GROUP 26 - ACCESSORIES, PUBLICATIONS, TEST EQUIPMENT AND TOOLS 2602.1—ACCESSORIES						
10	P	O	--	7520-559-9618	CASE, MAINTENANCE AND OPERATIONAL MANUALS: cotton duck, water-repellent, mildew-resistant.	--	--	1	1		
	P1	O	--	3431-509-2563	HOSE ASSEMBLY, GAS (88725) 21 N5942.	--	--	1	1		
	P	O	--	3439-779-6476	WIRE, ALUMINUM: 3/64 in. dia, 1-lb roll.	--	--	20	20		
					2602.2—COMMON TOOLS						
10	P	O	--	5120-277-9491	SCREWDRIVER, FLAT TIP: wood handle, flared tip 1/4 in. w, 4 in. lg blade.	--	--	1	*		
10	P	O	--	5120-228-7397	PLIERS, SLIP JOINT: straight nose, comb, w/cutter, 8 in. lg.	--	--	1	*		
10	P	O	--	5120-264-3796	WRENCH, OPEN END ADJUSTABLE: single head, 0 to 1 5/16 in. jaw opening, 12 in. lg.	--	--	2	*		
					2602.4—PUBLICATIONS						
12	--	--	--	-----	DEPARTMENT OF THE ARMY ORGANIZATIONAL, FIELD AND DEPOT MAINTENANCE MANUAL TM 5-3431-200-15.	--	--	2	2		
12	--	--	--	-----	DEPARTMENT OF THE ARMY OPERATOR, ORGANIZATIONAL, FIELD, AND DEPOT MAINTENANCE REPAIR PARTS AND SPECIAL TOOLLISTS TM 5-3431-200-25P.	--	--	2	2		

Technical service	Source codes		Federal stock No.	Description	Unit of issue	Expendability	Quantity authorized	Quantity issued with equipment	Illustration	
	Source	Maintenance Recoverability							Fig.	Item
				GROUP 44 - WELDING, METALIZING, METAL HEATING AND PLATING EQUIPMENT 4406.5—PROTECTIVE DEVICES, ELECTRICAL						
P	O	--	5920-280-4465	FUSE, CARTRIDGE: 1 amp, 250 v.-----	--	--	2	2		
P	O	--	5920-280-5062	FUSE, CARTRIDGE : 2 amp, 250 v, dc, 1- 1/4 in. lg.	--	--	4	4		
				4406.11—HEAD, TORCH AND GUN UNITIZED COMPONENTS						
P1	O	--	3431-875-7930	ADAPTER -----	--	--	1	1		
P	O	--	3431-446-2642	NOZZLE, GAS -----	--	--	7	7		
P1	O	--	3431 -875-7638	ROLL, DRIVE -----	--	--	1	1		
P	O	--	3431-446-2644	TUBE, GUIDE -----	--	--	36	36		

INDEX

	Paragraph	Page
Adapter nozzle-----	62	32
Adjustment, gas regulator-----	34a	19
Argon gas:		
Flow obstructed-----	43	22
Le a k s -----	42	23
Will not flow -----	38	22
Argon gas system:		
Gas pipe -----	49	23
General -----	48	23
Hose assembly -----	49	23
Solenoid valve -----	49	23
Testing -----	49c	23
Arm, swing -----	61	32
Barrel, gun -----	62	32
Basic issue tools and equipment -----	26	13
Bracket -----	87,88	43,44
Cable assemblies, grip, strain reliefs, power switch, and terminal strip -----	51	25
Power switch field expedient repair -----	51d	25
Cables :		
Control -----	87,88	43,44
C u r r e n t -----	61	32
Capacitors:		
Current relay -----	64	28
Teeting -----	54c	28
Gun handle assembly -----	87,88	43,44
Inching switch relay -----	60	32
Testing -----	60c	32
Rectifier filter -----	60	32
Testing -----	60c	32
Trigger switch relay -----	60	32
Testing -----	60c	32
Cold weather operation -----	19	10
Components, separately packed -----	9	7
Contacto r -----	53,85,86	27,42
Testing -----	53c	27
Catactor resistor -----	59	31
Testing -----	59c	31
Contacto r fails to close when trigger is pressed -----	79	41
Control:		
Assembly -----	4b, 74a	4,39
Cable -----	87,88	43,44
Panel assembly -----	55	28
Controls and instruments -----	13,14	8
Corps of Engineers identification plate -----	4a, 4b	4
Cover, welding gun -----	61	32
Current cable -----	61	32
Current relay, current relay capacitor, and receptacle -----	54	28
Capacitor testing -----	54c	28

	Paragraph	Page
Daily services, operator's -----	29	13
Data (see Tabulated data)		
Demolition:		
General-----	63	35
Other methods -----	65	35
To render welding set inoperative -----	64	35
Training-----	66	35
Description -----	3, 73	3,39
Diagrams, wiring:		
Practical-----	4b	4
Schematic-----	74c	39
Difference in models -----	5	6
Dimensions and weight -----	4b	4
Dismantling for movement -----	11	8
Drive roll -----	87,88	43,44
Dusty areas operation -----	21	10
Electrical system:		
Cable assemblies, grip, strain reliefs, power switch, and terminal strip -----	51	25
Power switch field expedient repair -----	51d	25
Contactor-----	53	27
Testing-----	53c	27
Contactor resistor-----	59	31
Testing-----	59c	31
Control panel assembly-----	55	28
Current relay, current relay capacitor, and receptacle -----	54	28
Capacitor testing -----	54c	28
General -----	50	25
Inching feed resistor -----	59	31
Testing-----	59c	31
Inching speed resistor -----	59	31
Testing-----	59c	31
Inching switch relay -----	58	31
Testing-----	58c	31
Inching switch relay capacitor -----	60	32
Testing-----	60c	32
Nozzle, adapter, guide tube, gun tube, gun barrel, and insulation -----	62	32
Rectifier-----	56	31
Testing-----	56c	31
Rectifier filter capacitor -----	60	32
Testing-----	60c	32
Rheostat resistor -----	52	25
Testing-----	52d	26
Trigger switch relay -----	57	31
Testing-----	57c	31
Trigger switch relay capacitor -----	60	32
Testing -----	60c	32
Welding gun cover, shield, fitting assembly, swing arm, and current cable -----	61	32
Welding wire feed control rheostat, rheostat resistor, and fuse holders -----	52	25
Testing		
Resistor -----	52d	26
Rheostat-----	52c	25

	Paragraph	Page
Equipment:		
Basic issue tools and	26	13
Dismantling for movement	11	8
Inspecting.....	8	7
Inspection in storage	70	37
Installation instructions	10	7
Installation of separately packed components	9	7
Loading for shipment	68	37
Maintenance in storage	70	37
Operation:		
At high altitudes	24	10
General	15	10
In dusty areas	21	10
In extreme cold (below 0°F.)	19	10
In extreme heat	20	10
In salt water areas	23	10
In sandy areas	21	10
Starting the welding set	16	10
Stopping the welding set	17	10
Under humid conditions	22	10
Under rainy conditions	22	10
Welding set	18	10
Preparation:		
For shipment	67	37
For storage	69	37
Reinstallation after movement	12	8
Setting-up instructions	10	7
Special tools and	25,75	13,41
Specially designed tools and	77	41
Unloading.....	7	7
Unpacking	6	7
Expedient repairs, field (see Field expedient repairs).		
Feed resistor, inching	59	31
Testing	59c	31
Field and depot maintenance repair parts	76	41
Field expedient repairs:		
General	45	22
Welder will not operate when power switch is placed in the ON position	47	23
Wire fails to feed when welding inching switch is pressed	46	23
Filter capacitor, rectifier	60	32
Testing	60c	32
Fitting assembly	61	32
Flowmeter manufacturer's data plate	4a, 4b	4
Forms, record and report	2, 72	3,39
Fuse holders	52	25
Fuse replacement	32	19
Gas pipe	49	23
Gas regulator, argon	4b, 34	4, 19
Adjustment	34a	19
Gas system, argon:		
Gas pipe	49	23
General	48	23
Hose assembly	49	23
Solenoid valve	49	23
Testing	49c	23

	Paragraph	Page
Grip -----	51	25
Guide tube-----	62	32
Gun:		
Barrel-----	62	32
Cover, welding-----	61	32
Service, welding-----	33	19
Tabulated data, welding-----	4b	4
Tube-----	62	32
Gun handle assembly:		
Bracket-----	88	44
Capacitor-----	88	44
Control cable-----	88	44
Drive roll-----	88	44
General-----	87	43
Gun handle assembly-----	88	44
Inching switch-----	88	44
Motor-----	88	44
Trigger switch-----	88	44
Handle assembly, gun (see Gun handle assembly).		
High altitude operation-----	24	10
Holders, fuse-----	62	25
Hose assembly, solenoid valve, and gas pipe -----	49	23
Solenoid valve teeting -----	49c	23
Hot weather operation -----	20	10
Humid conditions operation -----	22	10
Identification and tabulated data -----	4	4
Identification platen:		
Corps of Engineers-----	4a, 4b	4
Flowmater manufacturer's data -----	4a, 4b	4
Manufacturer's data -----	4a, 4b	4
Inching:		
Feed resistor-----	59	31
Testing-----	59c	31
Speed resistor -----	59	31
Testing -----	59c	31
Switch -----	87,88	43,44
Switch relay -----	58	21
Testing -----	58c	31
Switch relay capacitor -----	60	32
Testing -----	60c	32
Inspecting and servicing equipment -----	8	7
Inspecting and maintenance of equipment in storage -----	70	37
Installation of separately packed components -----	9	7
Installation or setting-up instructions -----	10	10
Instruments and controls -----	18,14	8
Insulation -----	62	32
Loading equipment for shipment -----	68	37
Maintenance:		
Operators:		
Argon gas regulator -----	34	19
Adjustment-----	34a	19
Fuse replacement -----	32	19
Welding gun -----	31	16
Organizational-----	33	19

	Paragraph	Page
Repair parts:		
Field and depot-----	76	41
Organizational -----	27	13
Services:		
Operator's daily-----	29	13
Preventive (see Preventive maintenance services),		
Quarterly -----	31	16
Maintenance of equipment in storage -----	70	37
Manufacturer's data plate -----	4a, 4b	4
Models, difference in -----	5	6
Motor -----	87,88	43,44
Testing -----	88e	45
Motor fails to run when inching switch is pressed -----	80	41
Movement to a new worksite:		
Dismantling for -----	11	8
Reinstallation after-----	12	8
Nozzle, adapter, guide tube, gun tube, gun barrel, and insulation -----	62	32
Operation of equipment:		
At high altitudes-----	24	10
General -----	15	10
In dusty areas-----	21	10
In extreme cold (below 0°F.) -----	19	10
In extreme heat -----	20	10
In salt water areas -----	23	10
In sandy areas -----	21	10
Starting the welding set -----	16	10
Stopping the welding set -----	17	10
Under humid conditions -----	22	10
Under rainy conditions -----	22	10
Welding set -----	18	10
Operator's daily services -----	29	13
Operator's maintenance:		
Fuse replacement -----	32	19
Gas regulator, argon -----	34	19
Adjustment -----	34a	19
Welding gun services -----	33	19
Organizational maintenance -----	30	16
Organizational maintenance repair parts -----	27	13
Panel assembly, control -----	55	28
Pipe, gas -----	49	23
Plates:		
Corps of Engineers identification -----	4a, 4b	4
Flowmeter manufacturer's data -----	4a, 4b	4
Manufacturer's data -----	4a, 4b	4
Power switch -----	51	25
Field expedient repair -----	51d	25
Preparation of equipment for shipment -----	67	37
Preparation for equipment for storage -----	69	37
Preventive maintenance services:		
Fuse replacement -----	32	19
Gas regulator -----	34	19
Adjustment -----	34a	19
General -----	28	13
Operator's daily -----	29	13
Organizational maintenance -----	30	16
Quarterly -----	31	16
Welding gun service -----	33	19

	Paragraph	Page
Quarterly preventive maintenance services -----	31	16
Rainy conditions operation -----	22	10
Receptacle-----	54	28
Record and report forms-----	2,72	3,39
Rectifier-----	56	31
Testing-----	56c	31
Rectifier filter capacitor -----	60	32
Testing -----	60c	32
Regulator, argon gas -----	4b, 34	4,19
Adjustment -----	34a	19
Reinstallation after movement -----	12	8
Relay capacitors:		
Current -----	54	28
Testing -----	54c	28
Inching switch -----	60	32
Testing -----	60c	32
Trigger switch -----	60	32
Testing -----	60c	32
Relays:		
Current-----	54	28
Inching switch -----	58	31
Testing -----	58c	31
Trigger switch -----	57	31
Testing -----	57c	31
Reliefs, strain -----	51	25
Repair (see Field expedient repairs).		
Report forms -----	2,72	3,39
Resistors:		
Contactor -----	59	31
Testing -----	59c	31
Inching feed -----	59	31
Testing -----	59c	31
Inching speed-----	59	31
Testing -----	59c	31
Rheostat -----	52	25
Testing -----	52d	26
Rheostat, rheostat resistor, and fuse holders, welding wire feed control -----	52	25
Testing:		
Resistor-----	52d	26
Rheostat -----	52c	25
Roll, drive-----	87,88	43,44
Salt water areas operation -----	23	10
Sandy areas operation-----	21	10
Scope -----	1,71	3,39
Services, preventive maintenance (see Preventive maintenance services).		
Servicing equipment -----	8	7
Setting-up instructions -----	10	7
Shield -----	61	32
Shipment:		
Loading equipment for -----	68	37
Preparation of equipment for -----	67	37
Special tools and equipment -----	25,75	13,41
Specially designed tools and equipment -----	77	41
Speed resistor, inching -----	59	31
Testing -----	59c	31
Solenoid valve -----	49	23
Testing -----	49c	23

	Paragraph	Page
Standards, time	74d	39
Starting the welding set	16	10
Stopping the welding set	17	10
Storage:		
Inspection of equipment in.....	70	37
Maintenance of equipment in.....	70	37
Preparation of equipment for.....	69	37
Strain reliefs.....	51	25
Strip, terminal	51	25
Swing arm	61	32
Switch relay capacitors:		
Inching.....	60	32
Testing.....	60c	32
Trigger.....	60	32
Testing.....	60c	32
Switch relays:		
Inching.....	58	31
Testing.....	58c	31
Trigger.....	57	31
Testing.....	57c	31
Switches:		
Inching.....	88	44
Power.....	51	25
Field expedient repair.....	51d	26
Trigger.....	88	44
Table I. Time Standards	74d	39
Tabulated data (Field and depot) :		
Control contractor.....	74a	39
Time standards.....	74d	39
Welding gun	74b	39
Wiring diagram	74c	39
Tabulated data (Operator and organizational maintenance) :		
Control assembly	4b	4
Corps of Engineers identification plate	4b	4
Dimensions and weight	4b	4
Flowmeter manufacturer's data plate.....	4b	4
Gas regulator	4b	4
Manufacturer's data plate	4b	4
Welding gun.....	4b	4
Wiring diagram	4b	4
Terminal strip.....	51	25
Testing:		
C o n t a c t o r	53c	57
Contactor Resistor	59c	31
Current relay capacitor	54c	28
Inching field resistor	59c	31
Inching speed resistor	59c	31
Inching switch relay	58c	31
Inching switch relay capacitor	60c	32
Rectifier	56c	31
Rectifier filter capacitor	60c	32
R h e o s t a t	52c	25
Rheostat resistor	52d	26
Solenoid valve	49c	23
Trigger switch relay	57c	31
Trigger switch relay capacitor	60c	32
Time standards	74d	39

	Paragraph	Page
Tools and equipment:		
Basic issue-----	26	13
Special-----	25,75	13, 41
Specially designed-----	77	41
Training, demolition-----	71	39
Trigger:		
Switch-----	87,88	43,44
Switch relay-----	57	31
Testing-----	57c	31
Switch relay capacitor-----	60	32
Testing-----	60c	32
Troubleshooting (Field and depot) :		
Contactor fails to close when trigger is pressed-----	79	41
General-----	78	41
Motor fails to run when inching switch is pressed-----	80	41
Welding set starts but fails to continue welding-----	84	42
Wire:		
Feed speed too fast-----	83	43
Feed speed too slow-----	82	41
Will not feed-----	81	41
Troubleshooting (operator and organizational) :		
Argon gas:		
Flow obstructed-----	43	22
Leaks-----	42	22
Will not flow-----	38	22
General-----	35	21
Welding gun shorts between nozzle and guide tube-----	39	22
Welding set:		
Starts but fails to keep welding-----	44	22
Will not start to weld-----	36	21
Wire:		
Feed speed too fast-----	41	22
Feed speed too slow-----	40	23
Will not feed-----	37	21
Tubes:		
Guide-----	62	32
Gun-----	62	32
Unloading the equipment-----	6	7
Unpacking the equipment-----	7	7
Valve, solenoid-----	49	23
Testing-----	49c	23
Weight and dimensions-----	4b	4
Welder will not operate when power switch is placed in the ON position-----	47	23
Welding gun:		
Cover, shield, fitting assembly, swing arm, and current cable-----	61	32
Service-----	33	19
Shorts between nozzle and guide tube-----	39	22
Tabulated data-----	4b, 74b	4,39
Welding set:		
Operation-----	18	10
Starts but fails to continue welding-----	84	42
Starts but fails to keep welding-----	44	22
Will not start to weld-----	36	21
Welding wire feed control rheostat-----	52	25
Testing-----	52c	25

	Paragraph	Page
Wire:		
Fails to feed when inching switch is pressed -----	46	23
Feed speed too fast -----	41,83	22,42
Feed speed too slow -----	40,47	22,23
Will not feed -----	37,81	21,41
Wiring diagrams:		
Practical -----	4b	4
Schematic -----	74c	39

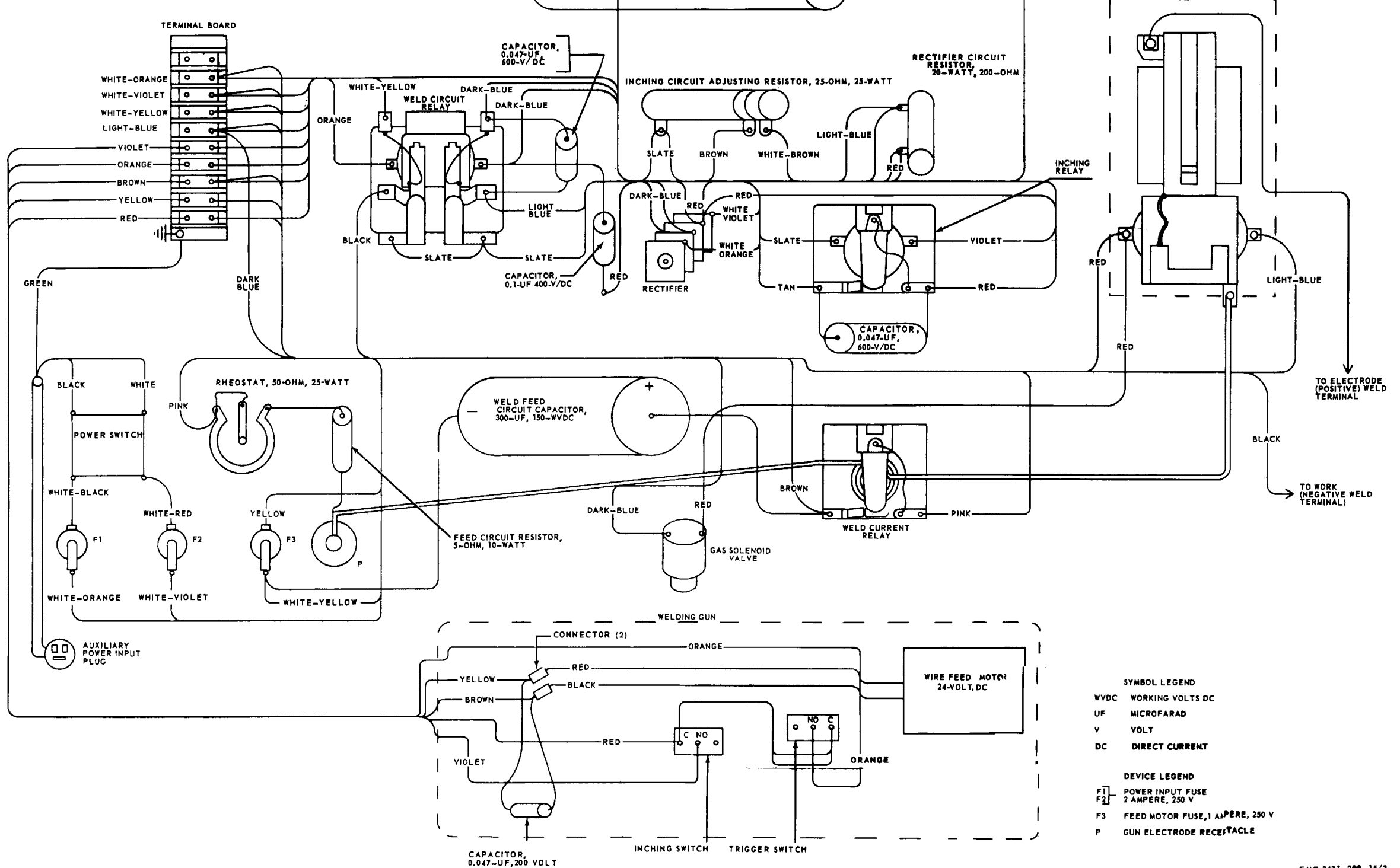

Figure 3. Practical wiring diagram.

BY ORDER OF THE SECRETARY OF THE ARMY:

Official:

J. C. LAMBERT,
Major General, United States Army,
The Adjutant General

G. H. DECKER,
General, United States Army,
Chief of Staff.

Distribution:

Active Army:

USASA (2)
DCSLOG (1)
CNGB (1)
Tech Stf, DA (1) except
CofEngrs (3)
Army Maint Bd (1)
USCONARC (3)
USAARTYBD (2)
USAARMBD (2)
USAIB (2)
USARADB (2)
USA Abn, Elct, & SPWAR
Bd (2)
USAAVNBD (2)
OS Maj Cored (5) except
USASETAF (2)
USARJ (10)
MDW (1)
Armies (2)
Corps (2)
Div (2)
Engr Bde (1)
Svc Colleges (2)
Br Svc Sch (2) except
USAES (100)
USMA (2)
GENDEP (2) except
Schenectady GENDEP (4)
Atlanta GENDEP (4)
Utah GENDEP (4)
Memphis GENDEP (4)
Sharpe GENDEP (4)
Engr Sec, GENDEP (10)
Engr Dep (10) except
Granite City Engr Dep (14)
OSA (2)
Engr Dist (2) except
Buffalo Engr Dist (1)
Chicago Engr Dist (1)
Detroit Engr Dist (1)
Alaska Engr Dist (1)
Los Angeles Engr Dist (1)
New Orleans Engr Dist (1)

New York Engr Dist (1)
Louisville Engr Dist (1)
Pittsburgh Engr Dist (1)
San Francisco Engr Dist (1)
Omaha Engr Dist (1),
Seattle Engr Dist (1)
Kansas City Engr Dist (1)
Baltimore Engr Dist (1)
Ft Worth Engr Dist (1)
Eastern Ocean Engr Dist (1)
Philadelphia Engr Dist (1)
Rock Island Engr Dist (1)
St Louis Engr Dist (1)
St Paul Engr Dist (1)
Div Engr Dist (2) except
Lower Miss Valley Div Engr (none)
North Central Div Engr (none)
Engr Fld Maint Shops (2)
Engr Dep Maint Shops (2)
USAERDL (3)
Engr Cen (5)
AMS (3)
USA Engr Proc Ofc (10)
EMC (26)
ESCO (10)
Fld Cored, DASA (8)
Def Log Svc Cen (1)
USACOMZEUR (2)
USAREUR Engr Sup Con Agcy (10)
USAREUR Engr Proc Cen (2)
USA Corps (1)
MAAG (1)
JBUSMC (1)
USA Trans Tml Comd (2)
Army Tml (1)
Units org under fol TOE:
5-48 (2)
5-237 (5)
5-262 (5)
5-267 (1)
5-278 (5)
5--279 (2)

NG: State AG (3).

USAR: Units—same as Active Army except allowance is one COpy to each unit.

For explanation of abbreviations used, AR 320-50.

RECOMMENDED CHANGES TO EQUIPMENT TECHNICAL PUBLICATIONS



THEN...JOT DOWN THE
DOPE ABOUT IT ON THIS FORM.
CAREFULLY TEAR IT OUT, FOLD IT
AND DROP IT IN THE MAIL.

SOMETHING WRONG WITH PUBLICATION

FROM: (PRINT YOUR UNIT'S COMPLETE ADDRESS)

DATE SENT

PUBLICATION NUMBER

PUBLICATION DATE

PUBLICATION TITLE

BE EXACT PIN-POINT WHERE IT IS

PAGE
NO.

PARA-
GRAPH

FIGURE
NO.

TABLE
NO.

IN THIS SPACE, TELL WHAT IS WRONG
AND WHAT SHOULD BE DONE ABOUT IT.

TEAR ALONG PERFORATED LINE

PRINTED NAME, GRADE OR TITLE AND TELEPHONE NUMBER

SIGN HERE

THE METRIC SYSTEM AND EQUIVALENTS

WEIGHT MEASURE

1 Centimeter = 10 Millimeters = 0.01 Meters = 0.3937 Inches
 1 Meter = 100 Centimeters = 1000 Millimeters = 39.37 Inches
 1 Kilometer = 1000 Meters = 0.621 Miles

WEIGHTS

1 Gram = 0.001 Kilograms = 1000 Milligrams = 0.035 Ounces
 1 Kilogram = 1000 Grams = 2.2 lb.
 1 Metric Ton = 1000 Kilograms = 1 Megagram = 1.1 Short Tons

LIQUID MEASURE

1 Milliliter = 0.001 Liters = 0.0338 Fluid Ounces
 1 Liter = 1000 Milliliters = 33.82 Fluid Ounces

SQUARE MEASURE

1 Sq. Centimeter = 100 Sq. Millimeters = 0.155 Sq. Inches
 1 Sq. Meter = 10,000 Sq. Centimeters = 10.76 Sq. Feet
 1 Sq. Kilometer = 1,000,000 Sq. Meters = 0.386 Sq. Miles

CUBIC MEASURE

1 Cu. Centimeter = 1000 Cu. Millimeters = 0.06 Cu. Inches
 1 Cu. Meter = 1,000,000 Cu. Centimeters = 35.31 Cu. Feet

TEMPERATURE

$5/9(^{\circ}\text{F} - 32) = ^{\circ}\text{C}$
 212° Fahrenheit is equivalent to 100° Celsius
 90° Fahrenheit is equivalent to 32.2° Celsius
 32° Fahrenheit is equivalent to 0° Celsius
 $9/5^{\circ}\text{C} + 32 = ^{\circ}\text{F}$

APPROXIMATE CONVERSION FACTORS

TO CHANGE	TO	MULTIPLY BY
Inches	Centimeters	2.540
Feet	Meters	0.305
Yards	Meters	0.914
Miles	Kilometers	1.609
Square Inches	Square Centimeters	6.451
Square Feet	Square Meters	0.093
Square Yards	Square Meters	0.836
Square Miles	Square Kilometers	2.590
Acres	Square Hectometers	0.405
Cubic Feet	Cubic Meters	0.028
Cubic Yards	Cubic Meters	0.765
Fluid Ounces	Milliliters	29.573
its	Liters	0.473
arts	Liters	0.946
allons	Liters	3.785
Ounces	Grams	28.349
Pounds	Kilograms	0.454
Short Tons	Metric Tons	0.907
Pound-Feet	Newton-Meters	1.356
Pounds per Square Inch	Kilopascals	6.895
Miles per Gallon	Kilometers per Liter	0.425
Miles per Hour	Kilometers per Hour	1.609

TO CHANGE	TO	MULTIPLY BY
Centimeters	Inches	0.394
Meters	Feet	3.280
Meters	Yards	1.094
Kilometers	Miles	0.621
Square Centimeters	Square Inches	0.155
Square Meters	Square Feet	10.764
Square Meters	Square Yards	1.196
Square Kilometers	Square Miles	0.386
Square Hectometers	Acres	2.471
Cubic Meters	Cubic Feet	35.315
Cubic Meters	Cubic Yards	1.308
Milliliters	Fluid Ounces	0.034
Liters	Pints	2.113
Liters	Quarts	1.057
ers	Gallons	0.264
ms	Ounces	0.035
ograms	Pounds	2.205
Metric Tons	Short Tons	1.102
Newton-Meters	Pounds-Feet	0.738
Kilopascals	Pounds per Square Inch	0.145
ometers per Liter	Miles per Gallon	2.354
ometers per Hour	Miles per Hour	0.621

